

ALL IMAGES ARE LEFT
HAND LOCKS

RIGHT HAND LOCKS
MIRRORED

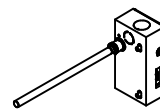

FIGURE 1

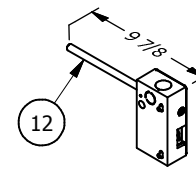

FIGURE 2

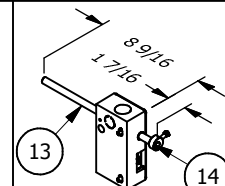
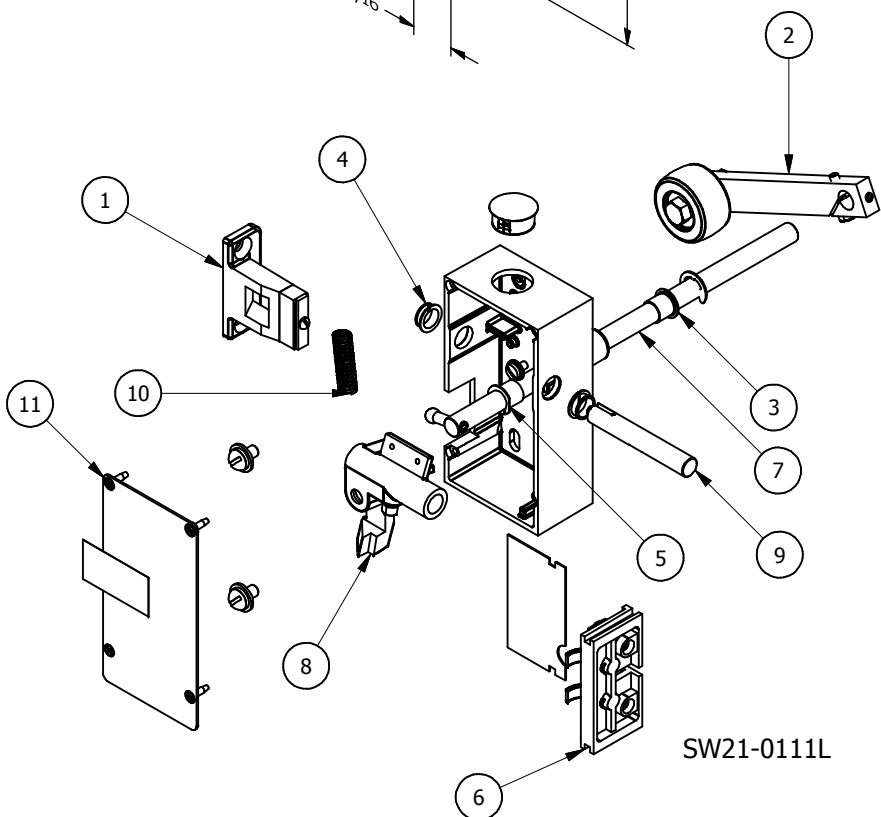
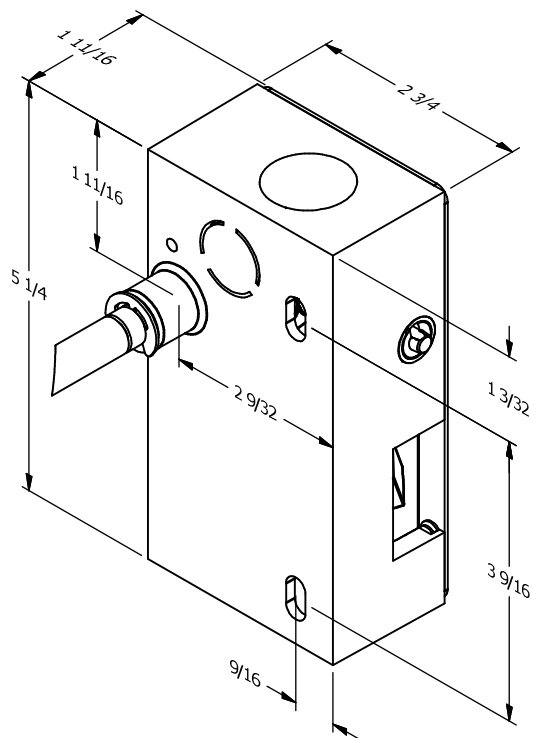
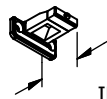
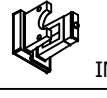
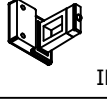
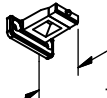

FIGURE 3



SW21-0111L

LOCK & CONTACT BOX NO ACTIVATING ARM OR KEEPER	SW21-0110L/R	SW21-0210L/R	N/A
 SURFACE INT4-0001N	SW21-0111L//R	SW21-0211L/R	N/A
 FLUSH INT4-0002N	SW21-0121L/R	SW21-0221L/R	N/A
 KALAMINE INT4-0003N	SW21-0131L/R	SW21-0231L/R	N/A
 SLIDE INT4-0004N	N/A	N/A	SW21-0341L/R

WITH 4.5" ARM & ROLLER & KEEPER

PARTS LIST

ITEM	QTY	PART NUMBER	DESCRIPTION
1	1	INT4-0001N	KEEPER,M/N INTERLOCK SWING DOOR
2	1	INT5-0025N	ARM & ROLLER, 4 1/2" CL
3	1	HWBS-0003N	BUSHING,NYLINER 7/16 ID
4	2	HWBS-0012N	BUSHING,TYPE 7 SNAP IN NYLINER 7/16" ID
5	1	HWBS-0045N	BUSHING, FLANGE MODIFIED 7/16 ID NYLINER
6	1	INT22-0022N	CONTACT ASSEMBLY, N/NHA INTERLOCK LOWER
7	1	INT5-0022N	SHAFT, "M/N" INTERLOCK BALL PIN 10" LG
8	1	INT6-0012L/R	CAM, ASSEMBLED SN LOCK LOCKING
9	1	INT6-0015N	SHAFT,3"LG SM LOCK CAM
10	1	SPG-0030N	SPRING,1 7/8" LG x 13/32" OD-0.050 WIRE
11	1	SW21-9001N	COVER ASSEMBLY
12	1	INT5-0021N	SHAFT,M/N INTERLOCK 10" CAM SWING DOOR
13	1	INT5-0023N	SHAFT,M/N INTERLOCK 10" CAM SLIDE DOOR
14	1	INT5-0028N	CLAMP, LOCK EMERGENCY UNLOCKING ASSY

TYPE "SN" LOCK & ELECTRICAL CONTACT

UNLESS OTHERWISE SPECIFIED DIMENSIONS ARE IN INCHES ---- (X.XX) = X.XX REF. = REFERENCE ONLY

G.A.L. MANUFACTURING CORP.
50 East 153rd St. Bronx, NY 10451 (718)292-9000
THIS DRAWING AND THE DESIGNS CONTAINED IN IT ARE THE SOLE PROPERTY OF G.A.L. MANUFACTURING CORP. IT IS FURNISHED UNDER THE CONDITION THAT IT SHALL NOT BE COPIED, LOANED OR OTHERWISE DISTRIBUTED OR DISPOSED OF, DIRECTLY OR INDIRECTLY, WITHOUT PRIOR WRITTEN PERMISSION.

SHEET 1 of 1 REV: B
PART/DOCUMENT #
8715