

# GALaxy IV – Quickstart

## KEB AC Geared Induction



CAUTION

Elevator control products must be installed by elevator personnel who have been trained in the construction, maintenance, repair, inspection, and testing of elevator equipment. The elevator personnel must comply with all applicable safety codes and standards.



CAUTION

Every safety precaution, whether or not specifically stated in this document, must be implemented when installing, adjusting or servicing elevator equipment. All safety precautions must be followed to ensure the safety of elevator personnel and the general public.

### 1.0 Requirements for a running platform during initial startup

- 1.1 Wire Motor and Main Line Power as shown in the job connection diagrams.
- 1.2 Install and wire Governor as shown in the job connection diagrams.
- 1.3 Wire the motor encoder cable as shown in the job connection diagrams.
- 1.4 If controller is equipped with dynamic braking resistors, wire the DBR temperature sensor to the temperature sensor board.
- 1.5 Add temporary connections on the GALX-1102 Main I/O Board and Expansion I/O boards as shown in Figures 1, 2, 3, and 4.
- 1.6 Set the toggles switches on the GALX-1102 Main I/O Board as show in Figure 4.
- 1.7 Check/set parameters in the controller LCD user interface. See “GALaxy IV Controller Settings” in Table 1.
- 1.8 Check/set parameters in the KEB drive. See “KEB AC Geared Drive Settings” in Table 2.
- 1.9 Verify the PIC and PAL fault LED’s are off. See the GALX-1102AN Main I/O Board in Figure 4. If these LED’s are on, refer to the GALaxy IV adjustment manual for possible causes of these faults.
- 1.10 Perform the KEB Motor Learn procedure. The Motor Learn procedure is described on page 4.
- 1.11 Verify that the motor rotation direction and speed are correct. If the motor rotation direction and speed are not correct, verify that the LE03 parameter in the drive is set to the correct value. See page 4 for determining the proper setting for the LE03 parameter.



CAUTION

All temporary connections must be removed before placing the elevator in service. Refer to the GALaxy IV Manual for complete adjustment procedures.

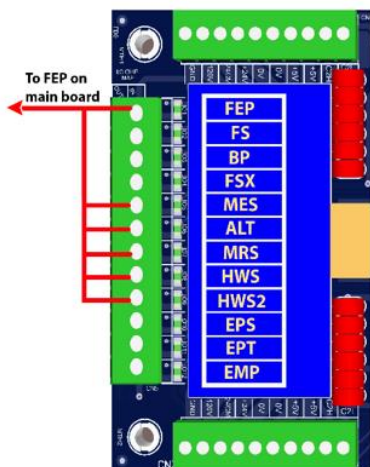

Figure 1: Typical I/O Expansion Board Fire I/O Board

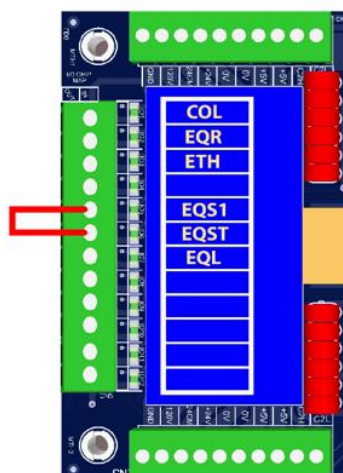

Figure 2: Typical I/O Expansion Board Earthquake I/O Board (if used)

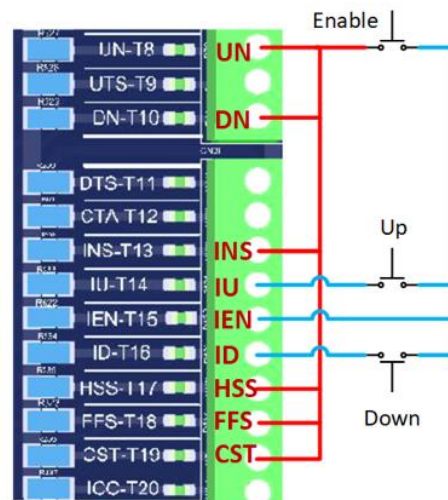

Figure 3: GALX-1102AN Main I/O Board With Run Bug. See Figure 4 For Run Bug Stop Switch

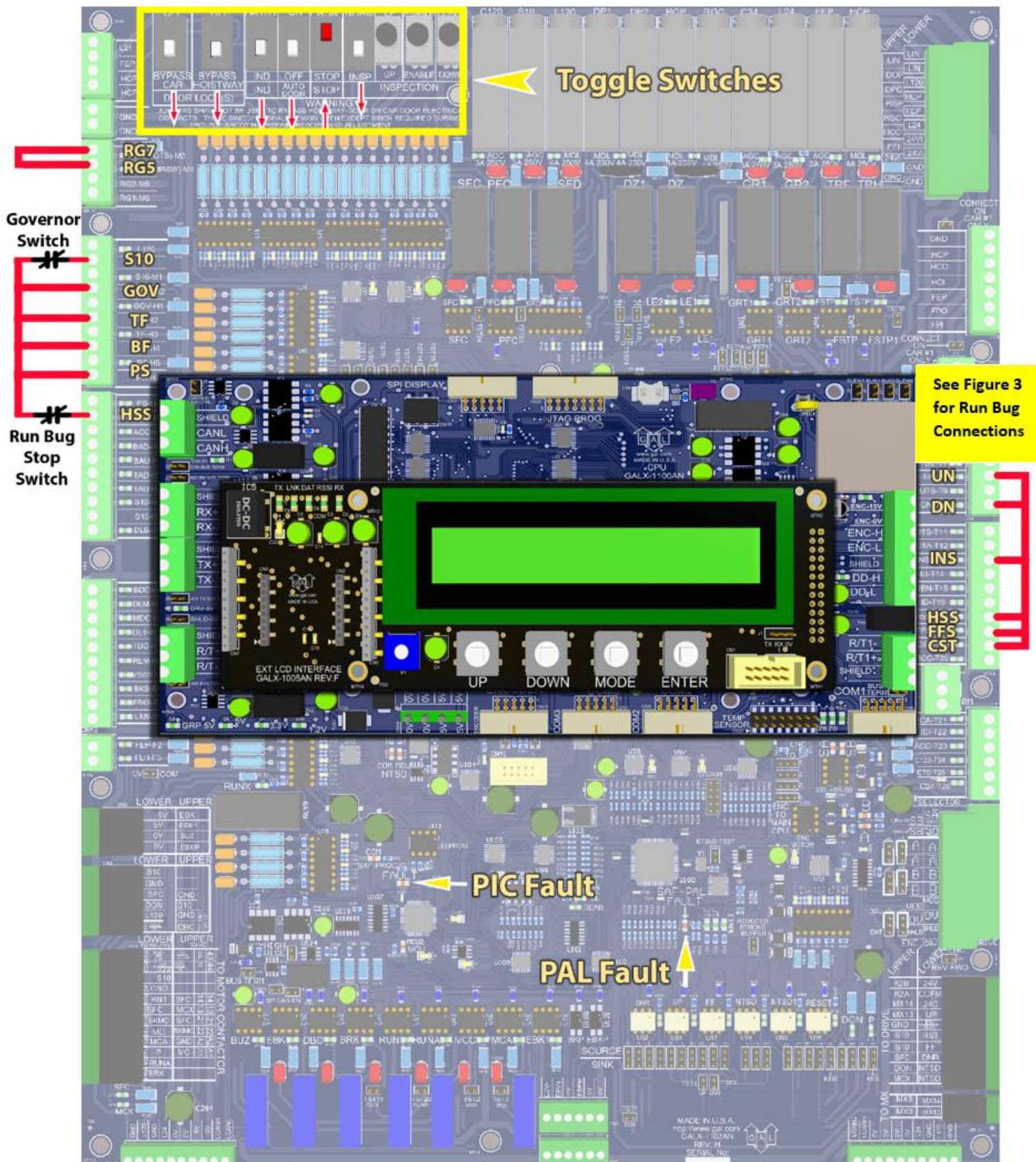

Figure 4: GALX-1102AN Main I/O Board

## Table 1: GALaxy IV Controller Settings

Preset the following parameters from the LCD User Interface “Adjustable Variables” menu.

Safety Processor Adjustable Variables Submenu (Motor Encoder Speed Feedback):	
Top Speed (contract speed fpm)	INSP Velocity (set to 140)
Encoder RPM (set to motor rpm)	Leveling Vel (set to 140)
Encoder PPR (set to motor encoder PPR)	ETS UP VEL (set to Top Speed – only used for reduced stroke buffer)
Encoder Type (set to 4 = incremental)	ETS DOWN VEL (set to Top Speed – only used for reduced stroke buffer)
Control Type (set to 2 = Tract DF)	Soft Stop Time (set to 3)
2 Stop (0 = Multi – Stop; 1 = 2 Stop)	PAL ETS UP Vel (set to Top Speed)
Rear Doors (0 = Front Only; 1 = Rear)	PAL ETS DN Vel (set to Top Speed)
UTS Velocity (set to Top Speed)	
DTS Velocity (set to Top Speed)	
NTS Processor Adjustable Variables Submenu	
Top Speed (contract speed fpm)	DT Velocity (set to Top Speed)
Encoder RPM (set to motor rpm)	UT1 Velocity (set to Top Speed)
Encoder PPR (set to motor encoder PPR)	DT1 Velocity (set to Top Speed)
Encoder Type (set to 0 if using APS; set to 1 if using tapeless)	UTn Velocity (set to Top Speed)
UT Velocity (set to Top Speed)	DTn Velocity (set to Top Speed)
Car Motion Submenu	
When Using Tapeless Selector:	When Using APS Selector:
Top Speed (set to Contract Speed)	Top Speed (set to Contract Speed)
Inspect Speed (set to 25 FPM)	Inspect Speed (set to 25 FPM)
Encoder PPR (set to 10,000 PPR)	Encoder PPR (not Used)
Encoder RPM (set to governor RPM)	Encoder RPM (not used)
Motor RPM (= LM02 value in KEB drive)	Motor RPM (LM02 value in KEB Drive)
System Options Submenu	
Drive Baud Rate = 2 (57,600)	KEB Dpy Type = 1 (LCD Display)
Encoder Type = 0	
EPRS Controller Parameters =>Adjustable Variables => Modified Motion	
EP Recov Speed = 15	
EP Top Speed = 15	
EP Target Dist = 2	

## Table 2: KEB AC Geared Drive Settings

Preset the following parameters from the KEB drive keypad

Drive Mode Settings (First):		
US03	Motor Type	= Induction Geared
US04	Control Type	= Serial Speed DIN66019 serv 49
LI15	Direction Selection Inputs	= UP & DN, Serial Control Word + Function by Dir. Inputs
US05	Load Configuration	= Write Config. To Drive
Control Settings		
LC01	Closed Loop FOC	=2
LC03	KP Speed Acceleration	= 3000
LC04	KP Speed Deceleration	= 3000
LC08	KI Speed Acceleration	= 250
LC09	KI Speed Deceleration	= 250
Encoder Data		
LE01	Encoder Interface	= Incremental
LE02	Encoder PPR	= Motor Encoder PPR
LE03	Swap Encoder Channels	= (See page 4 or KEB manual)
LE05	Encoder Multiplier	= 2 (Geared)
Motor Data		
LM01	Motor HP	= Nameplate HP
LM02	Rated Motor Speed	= Nameplate Full Load RPM
LM03	Rated Motor Current	= Nameplate AMPS
LM04	Rated Motor Frequency	= Nameplate HZ
LM05	Rated Motor Voltage	= Motor Voltage
LM06	Motor Power Factor	= 0.9 (if unknown)
LM08	Electric Motor Protection	= ON
LM09	Ele. Mtr. Protect. Current	= Nameplate AMPS
Machine Data		
LN01	Sheave Diameter	= inches
LN02	Gear Reduction Ratio	= Nameplate value
LN03	Roping Ratio	= 1.1 or 2.1
LN04	Load Capacity	= Car Capacity
When Using EPRS (UPS Emergency Power Rescue)		
LI04	Input 1 Function (I1)	= UPS Operation
LS10	Battery Operation Speed	= 15 ft / min
LT03	Speed Start Delay	= 2.5 sec
LT10	Brake Drop Delay	= 0.1 sec

**Motor Learn Procedure:**

- 1) Set "Inspect Speed" in the "Adjustable Variables Car Motion" submenu to 0.
- 2) Prevent the main machine brake from lifting.
- 3) Set **LL01 (Motor Tuning) = Start** in the KEB drive.
- 4) Initiate and up or down inspection command until the KEB keypad displays "*Calculation Complete*" (takes 2 to 5 minutes).
- 5) Set "Inspect Speed" in the "Adjustable Variables Car Motion" submenu to the desired value.
- 6) Return the main machine brake to its proper operating state.

**Determining LE03 Setting (Motor direction & A/B channels).**

**LE03: 0 = Nothing reversed**

**1 = A/B Swapped**

**2 = Inverted Rotation**

**3 = A/B Swapped & Inverted Rotation**

- 1) Run the elevator on inspection. Is the motor turning in the correct direction? If Yes, then set LE03=Nothing Reversed. If No, then set LE03=Inverted Rotation.
- 2) Run the elevator UP on inspection, empty car. Is the **Motor Current** too high? If Yes, then set LE03=A/B Swapped. If No, then set LE03=Nothing Reversed.
- 3) If the motor turns in the wrong direction AND the **Motor Current** is too high, then set to LE03=A/B Swapped & Inverted rotation.