

HALL STATION: FLUSH-MOUNTED

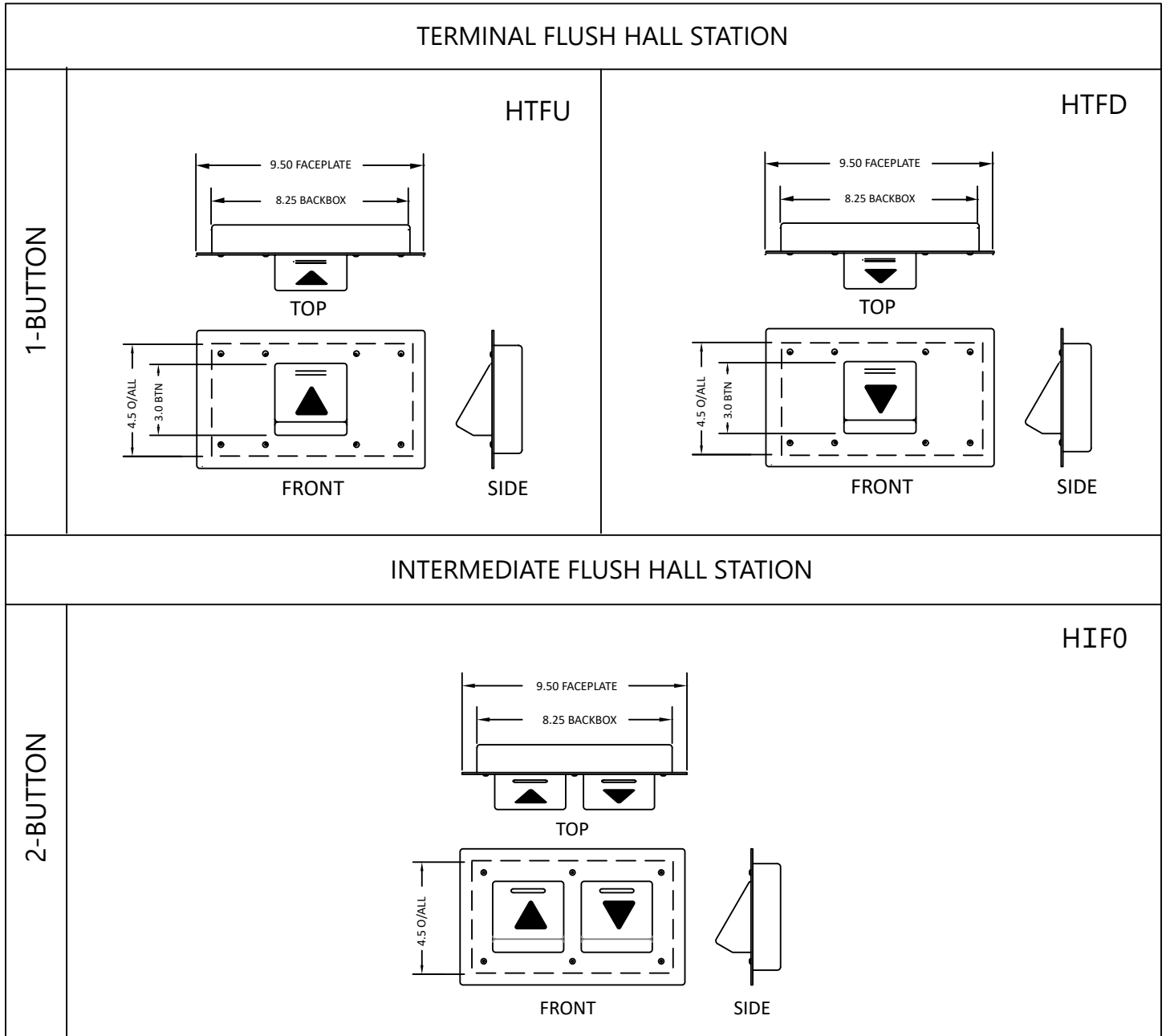

HALL STATION: SURFACE-MOUNTED

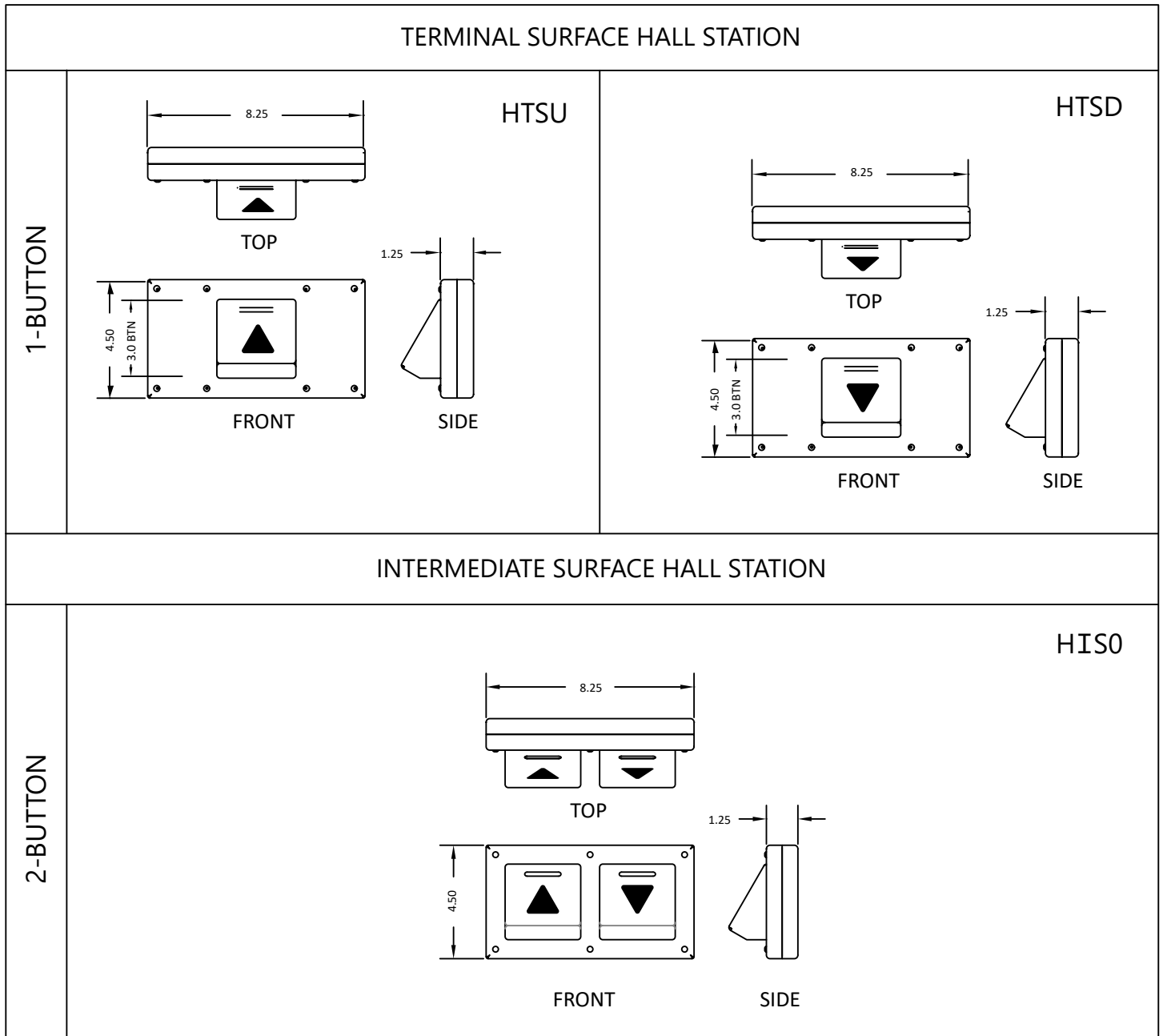

CAR STATION: SINGLE ROW

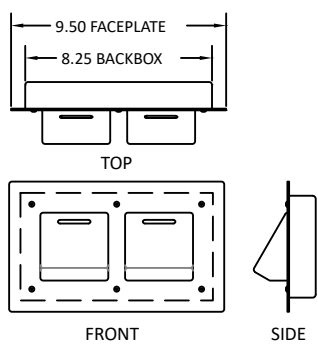
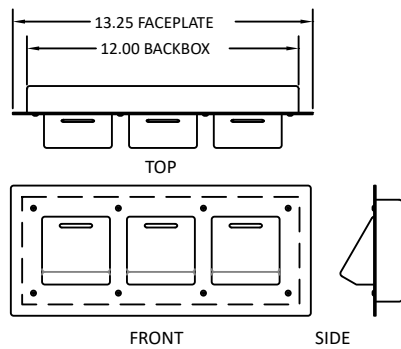
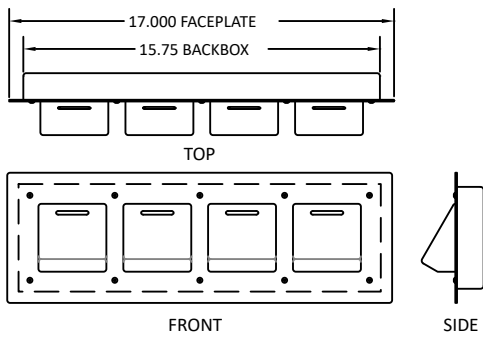
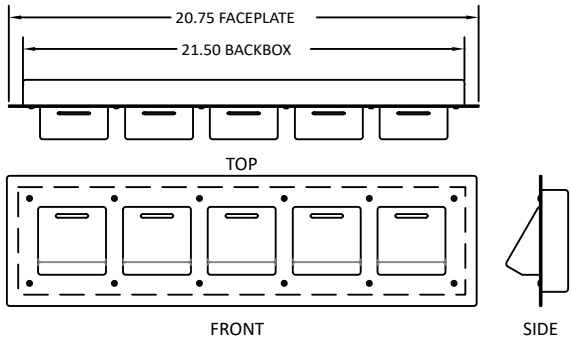
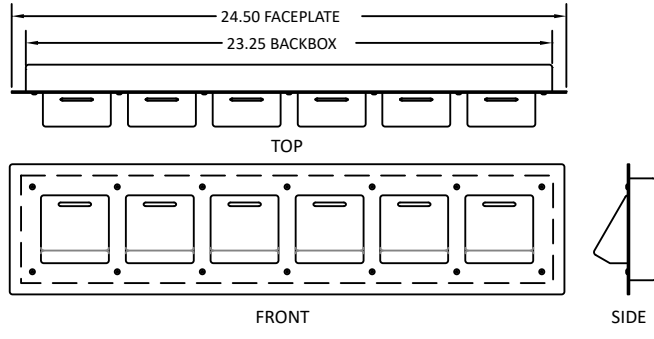
2-BUTTON	<p>C1X2</p>  <p>9.50 FACEPLATE 8.25 BACKBOX</p> <p>TOP</p> <p>FRONT</p> <p>SIDE</p>
4-BUTTON	<p>C1X3</p>  <p>13.25 FACEPLATE 12.00 BACKBOX</p> <p>TOP</p> <p>FRONT</p> <p>SIDE</p>
6-BUTTON	<p>C1X4</p>  <p>17.00 FACEPLATE 15.75 BACKBOX</p> <p>TOP</p> <p>FRONT</p> <p>SIDE</p>
3-BUTTON	<p>C1X5</p>  <p>20.75 FACEPLATE 21.50 BACKBOX</p> <p>TOP</p> <p>FRONT</p> <p>SIDE</p>
6-BUTTON	<p>C1X6</p>  <p>24.50 FACEPLATE 23.25 BACKBOX</p> <p>TOP</p> <p>FRONT</p> <p>SIDE</p>

CAR STATION: DOUBLE ROW

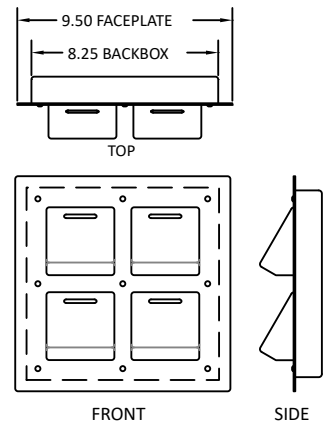
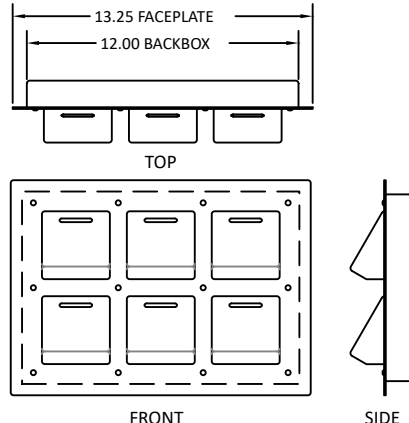
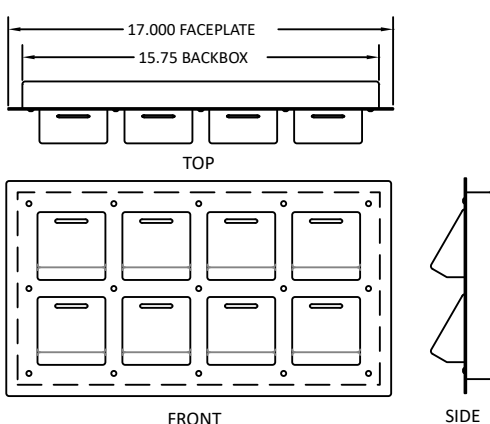
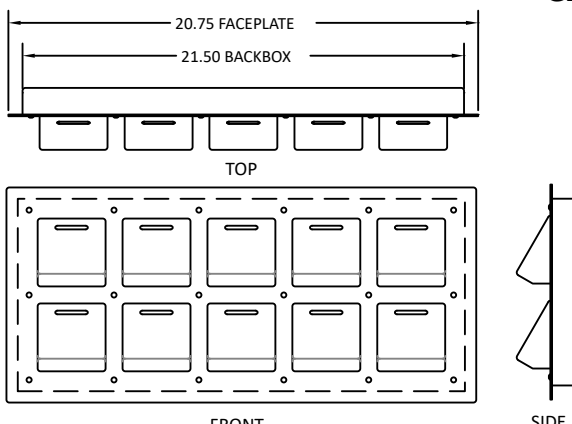
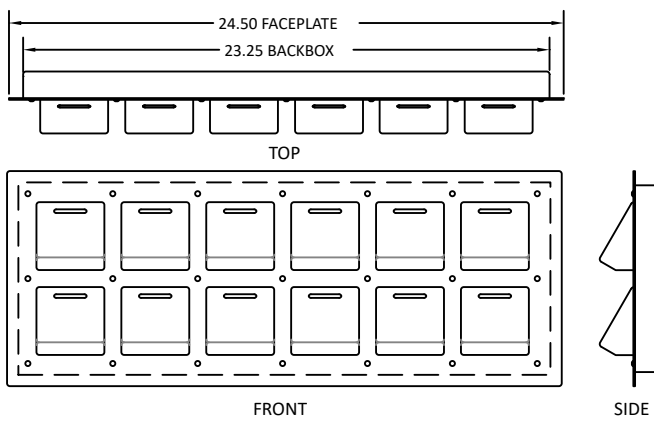
4-BUTTON	<p data-bbox="649 168 730 210">C2X2</p>  <p data-bbox="389 346 430 367">TOP</p> <p data-bbox="381 609 438 630">FRONT</p> <p data-bbox="560 609 600 630">SIDE</p>
	<p data-bbox="1421 168 1502 210">C2X3</p>  <p data-bbox="1096 346 1136 367">TOP</p> <p data-bbox="1088 609 1144 630">FRONT</p> <p data-bbox="1323 609 1364 630">SIDE</p>
8-BUTTON	<p data-bbox="649 703 730 745">C2X4</p>  <p data-bbox="389 892 430 913">TOP</p> <p data-bbox="373 1144 438 1165">FRONT</p> <p data-bbox="649 1144 690 1165">SIDE</p>
	<p data-bbox="1421 703 1502 745">C2X5</p>  <p data-bbox="1096 892 1136 913">TOP</p> <p data-bbox="1088 1144 1144 1165">FRONT</p> <p data-bbox="1404 1144 1445 1165">SIDE</p>
12-BUTTON	<p data-bbox="1421 1260 1502 1302">C2X6</p>  <p data-bbox="771 1428 812 1449">TOP</p> <p data-bbox="755 1680 820 1701">FRONT</p> <p data-bbox="1112 1680 1153 1701">SIDE</p>

CAR STATION: KEYPAD

DOUBLE ROW

K2X6

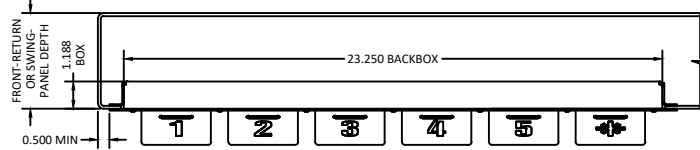

TOP VIEW

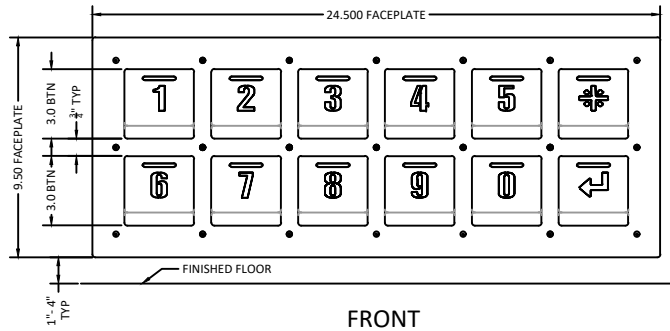

FRONT

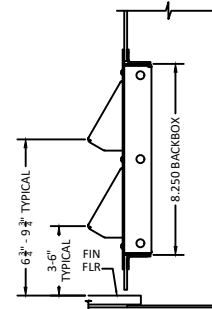

SIDE

TRIPLE ROW

K3X4

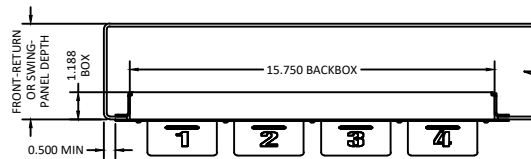

TOP VIEW

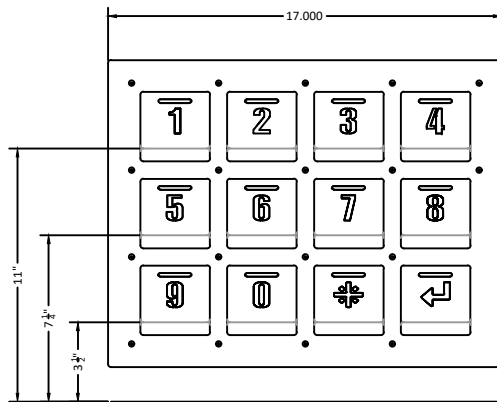

KEYPAD VERSION 3x4 VERSION
W/ FULL-SIZED BUTTONS (3" SQ)

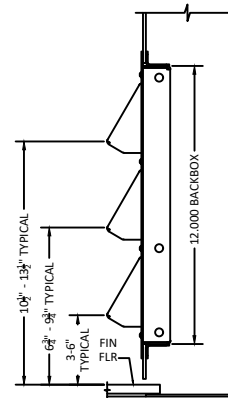

SIDE

HALL STATION FLUSH-MOUNTED DETAILS

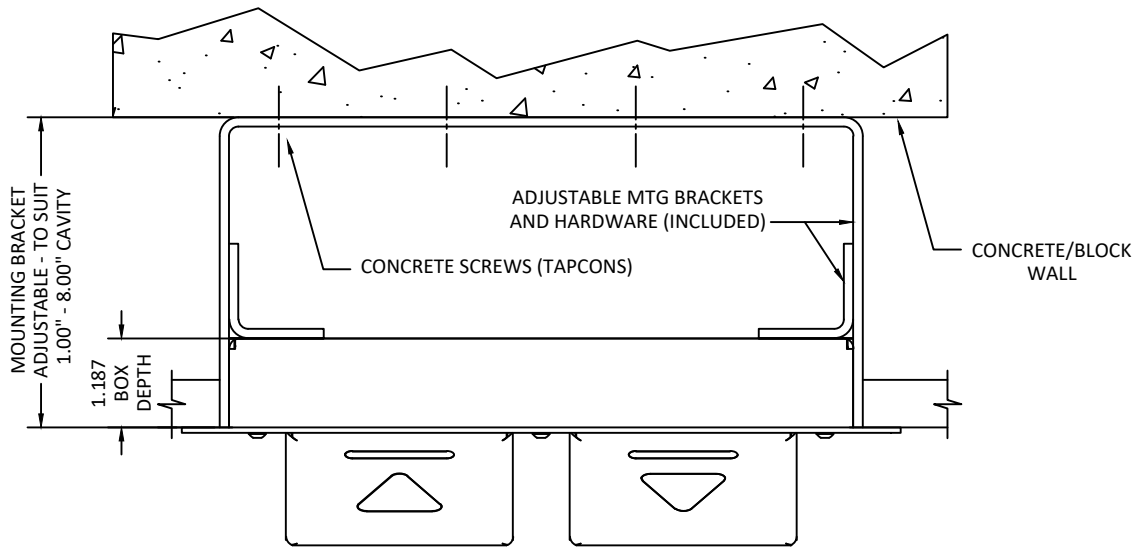

TOP VIEW

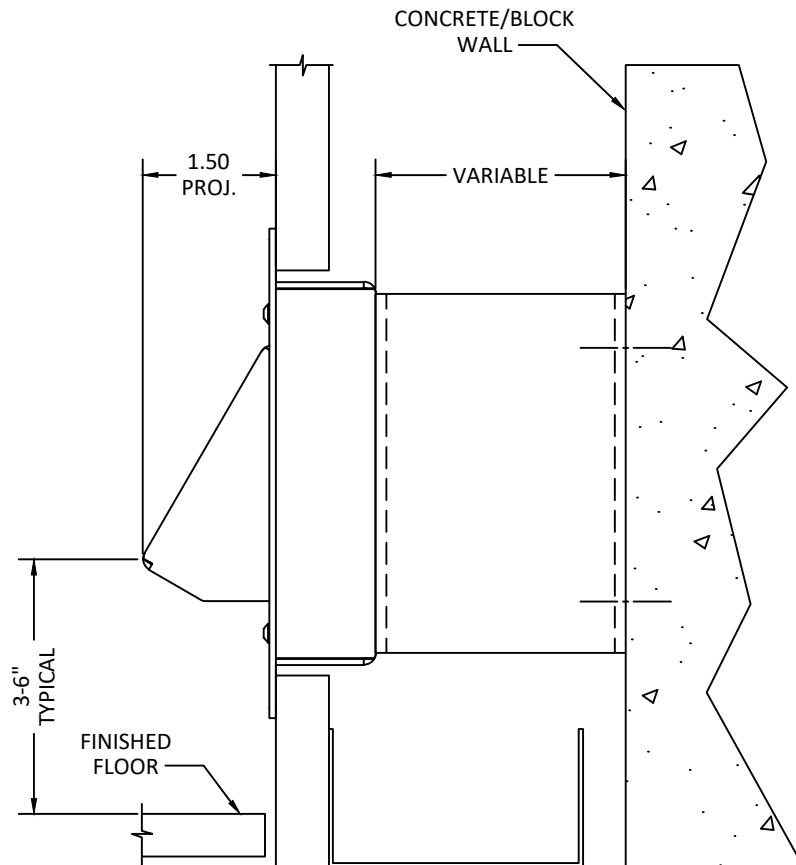

SIDE VIEW
(TYPICAL PARTITION
CONSTRUCTION)

HALL STATION: SURFACE-MOUNTED INSTALLATION DETAILS

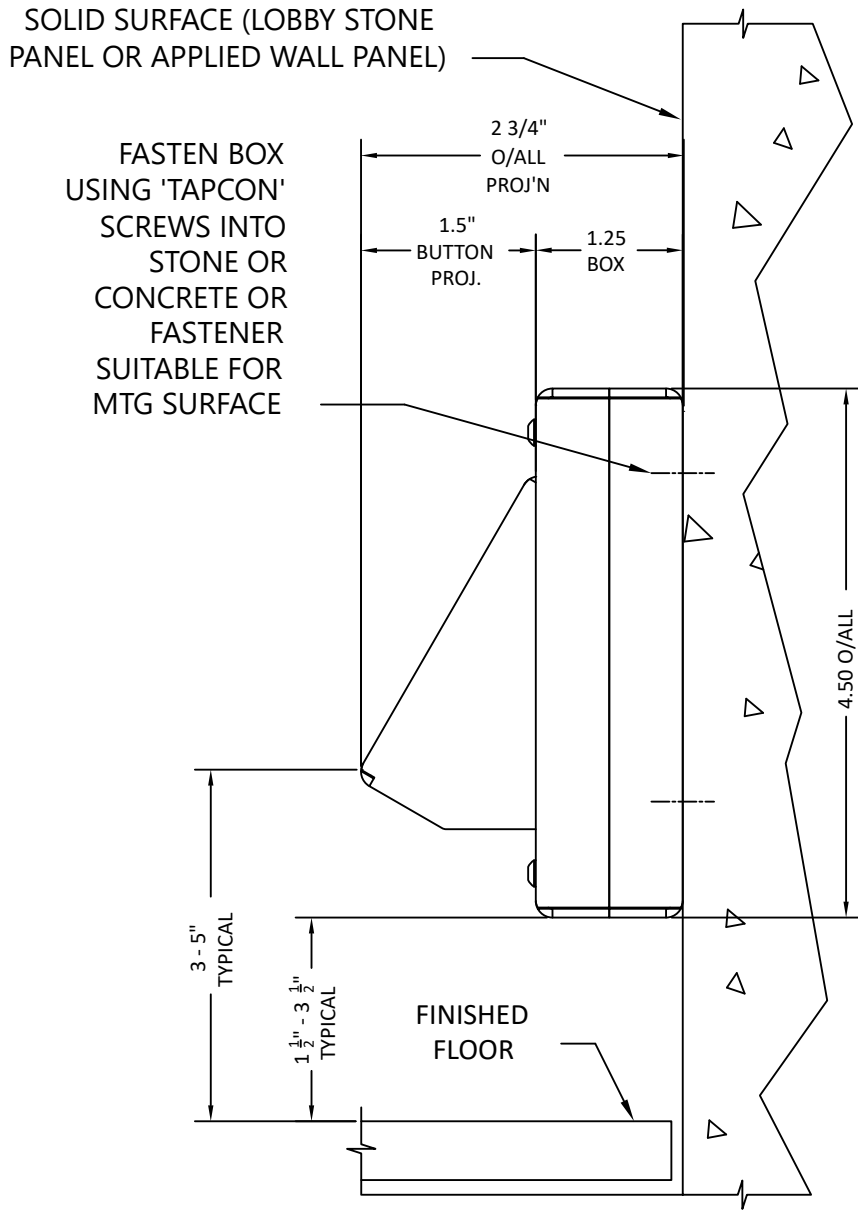

SURFACE-MTD - SIDE ELEVATION

CAR STATION: INSTALLATION DETAILS

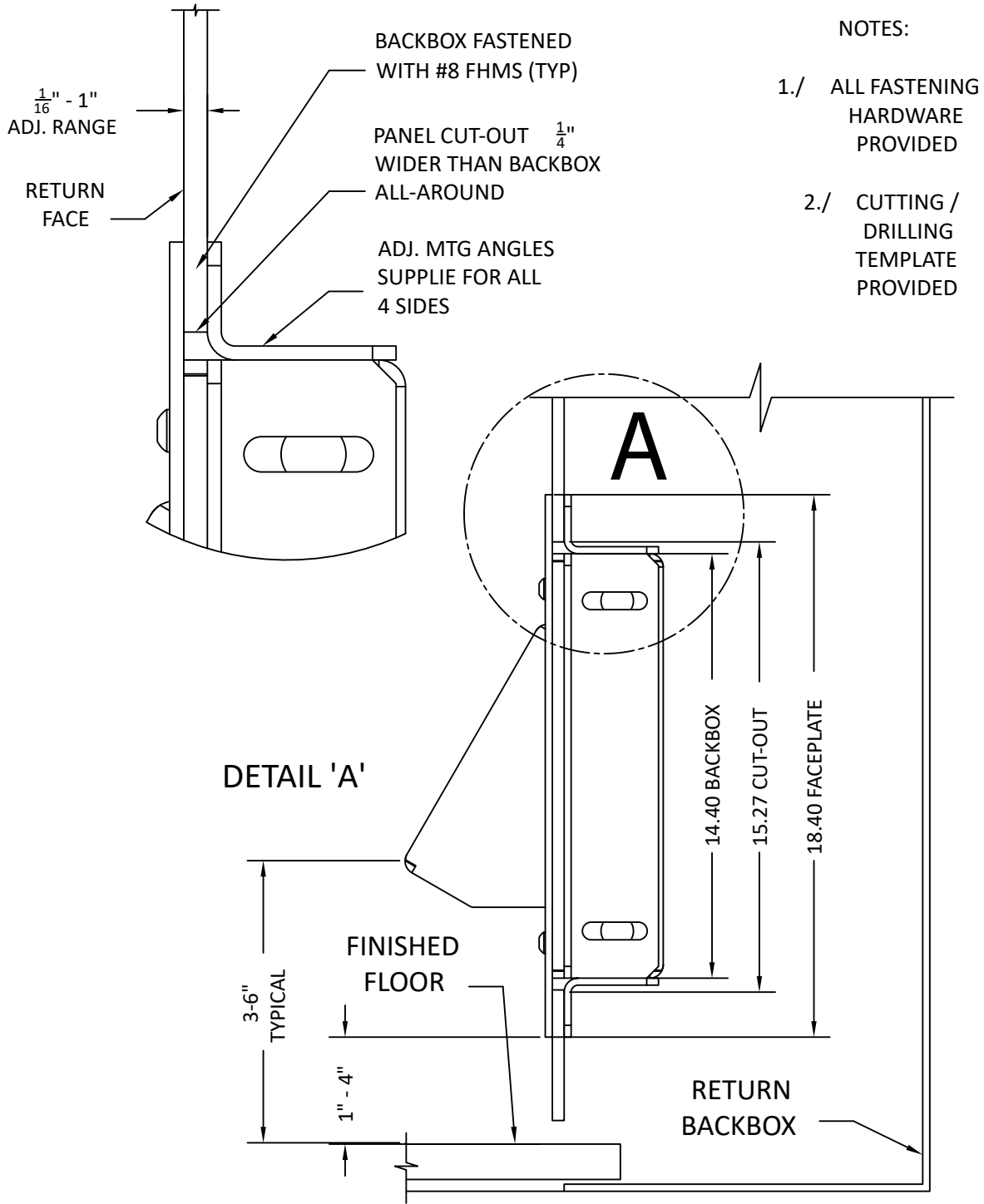

COP FLUSH-MTD - SECTION THRU FRONT RETURN / SWING PANEL