

FIGURE 1

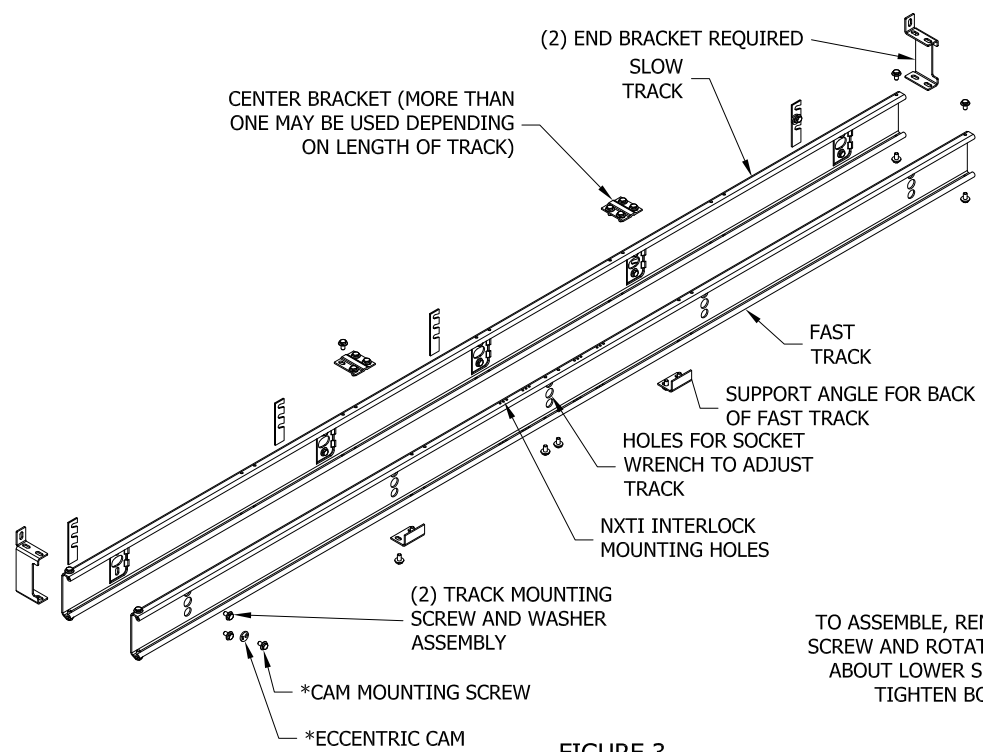
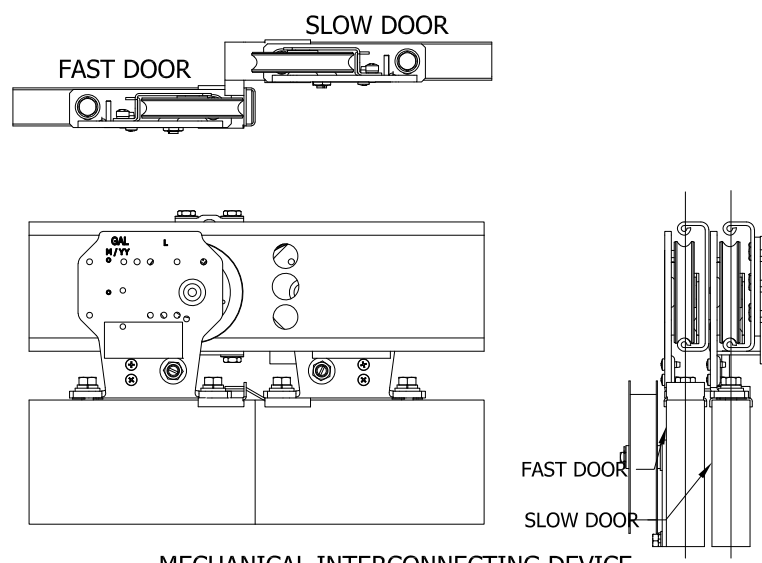
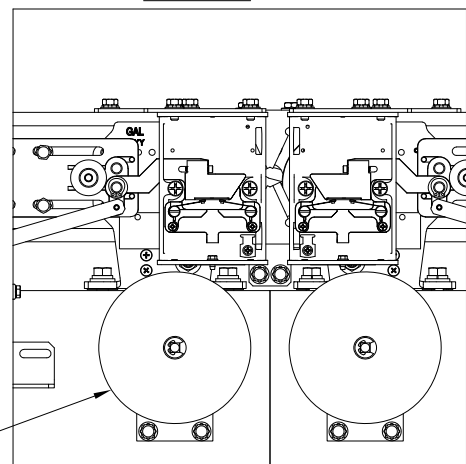

FIGURE 3



MECHANICAL INTERCONNECTING DEVICE

RIGHT HAND SHEAVE
FIGURE 4



62-73 DOOR OPENING

NOTE:
1. SLOW SPEED TRACK COMES ASSEMBLED WITH ALL BRACKETS.

INSTALLATION INSTRUCTIONS:

1. MOUNT SLOW TRACK TO HEADER AND SET ECCENTRIC CAM SO THAT THE TRACK IS IN THE LOWEST POSITION. HAND TIGHTEN ALL SCREWS.
2. HANG SLOW SPEED DOOR AND ROTATE ECCENTRIC CAM TO RAISE DOOR TO REQUIRED SILL CLEARANCE. ADJUST UPTHRUST ROLLERS TO CLEAR TRACK BY APPROXIMATELY 1/64 INCH.
3. CHECK DOOR ALIGNMENT IN OPENED AND CLOSED POSITION AND CORRECT PER FIGURE 2. IF REQUIRED, READJUST SLOW SPEED TRACK.
4. TIGHTEN ALL SCREWS.
5. MOUNT FAST SPEED DOOR TRACK.
6. MOUNT FAST SPEED DOOR. CHECK DOOR ALIGNMENT AND CORRECT PER FIGURE 2.

TWO SPEED CENTER OPENING HATCH DOOR ASSEMBLY

UNLESS OTHERWISE SPECIFIED DIMENSIONS ARE IN INCHES
THIRD ANGLE PROJECTION

DIMENSIONAL TOLERANCES	
X.XX	±0.01
X.XXX	±0.005
X.XXXX	±0.0005
ANGULAR	±0.5°

(X.XX) = X.XX REF. = REFERENCE ONLY (INSPECTION ID #) DIMENSION

G.A.L. MANUFACTURING CO.
50 East 153rd St. Bronx, NY 10451 (718)292-9000
THIS DRAWING AND THE DESIGNS CONTAINED IN IT ARE THE SOLE PROPERTY OF G.A.L. MANUFACTURING CO. IT IS FURNISHED UNDER THE CONDITION THAT IT SHALL NOT BE COPIED, LOANED OR OTHERWISE DISTRIBUTED OR DISPOSED OF, DIRECTLY OR INDIRECTLY, WITHOUT PRIOR WRITTEN PERMISSION.

DRAWN BY: **SRB**
DATE: **2/28/2020**
ENGINEER: **E. YANEZ**
SHEET **1** OF **1** REV: **A**
PART/DOCUMENT #:
8254-MONXT

REV	DESCRIPTION	DATE	ECN #
A	INITIAL RELEASE	2/28/2020	0831