

GAL Conversion Kit **MOVFE-HL** to replace existing SEC **QKS16** Linear and IDD Operators

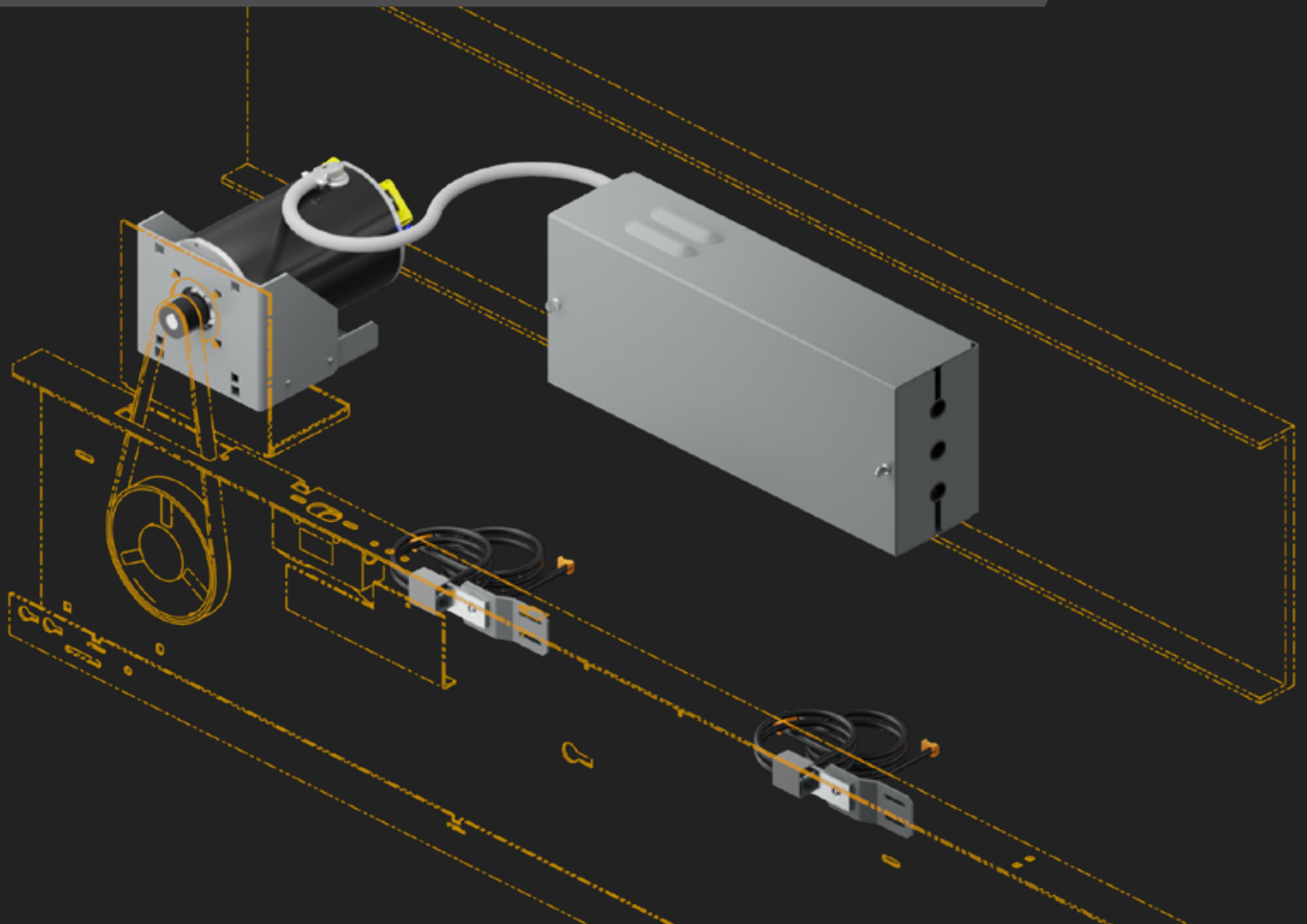

INSTALLATION GUIDE

RETAINING EXISTING HEADER, TRACKS, HANGERS,
CLUTCH, AND INTERLOCKS

DOC-0140N
REV B - 10.12.22



A **VANTAGE** Company

50 E. 153rd St.
Bronx, NY 10451-2104
Ph: 718.292.9000
Fax: 718.292.2034

info@gal.com
www.gal.com
sales@vantageelevation.com
www.vantageelevation.com



Chicago	877.300.5830
New York	917.336.4597
Miami	877.241.9354
L.A.	877.300.5816
Dallas	469.706.9316
Toronto	888.425.2262

**GAL CONVERSION KIT MOVFE-HL TO REPLACE
EXISTING SEC QKS16 LINEAR AND IDD OPERATORS**

(intentionally left blank)



CONTENTS

1. INTRODUCTION	1
2. INSTALLATION AND SETUP	2
2.1. COMPONENTS	2
2.2. PRELIMINARY STEPS	3
2.3. MOTOR REPLACEMENT	3
2.4. SENSOR MOUNTING	4
2.5. FIELD WIRING DIAGRAM	6
2.6. INITIAL ELECTRICAL SETUP	8
2.7. LED INDICATORS	10
2.8. MOVFE-HL DRIVE	11
2.9. PARAMETER UNIT	12
3. FAULTS LIST	23
4. KINETIC ENERGY AND ASME A17.1 2000	27

1. INTRODUCTION

It is the intent of this manual to give the reader certain key points of information critical to the proper installation of the door operator conversion kit. This retrofit kit is designed to replace the drive components of an existing SEC QKS16 or IDD operator with GAL's MOVFE-HL operator.

The existing QKS16 header, tracks and hangers are retained, allowing the user to easily replace the motor and add door sensors and controls instead of removing the entire header assembly and rehanging the doors.

When properly installed, GAL door operators will give many years of trouble-free service and reliability.

IMPORTANT NOTES

All equipment must be installed, adjusted, tested, and maintained to comply with all Federal, State/Provincial, and Local codes.

Kinetic Energy and Stall Force must be adjusted to comply with ASME, A17.1, Rule 112.4/5, and CSA/B44, Rule 2.13.4/5.

Before mounting the operator, check that the car door is plumb, free and moves easily without binding. Check the attached standard measurement sheets and install the operator according to the measurements supplied.

Contact GAL if the following label shown in *Figure 1* is missing from the door operator.



Figure 1: MOVFE Data Label

2. INSTALLATION AND SETUP

2.1. COMPONENTS

Each MOD kit contains the following components:

- Parameter unit with cable
- Installation Manual
- Sensor Assembly (2)
- Motor Assembly
- Drive unit Assembly (230V or 115V)
- Wiring Harness (2)
- Mounting Hardware Kit

2.2. PRELIMINARY STEPS

Remove the car from service, in compliance with standard safety policies. Disconnect the existing operator from the controller. Leave the existing gate switch wired and installed. It will be used with the new configuration.



Figure 2: Existing Gate Switch

2.3. MOTOR AND DRIVE REPLACEMENT

Loosen the jack bolt to remove the Multi-V Belt and save this for later. Remove the QKS16 motor assembly.

Mount the GAL adaptor and motor assembly to the existing QKS16 motor plate using (4) bolts. The GAL motor bracket assembly has (10) openings for snap nuts. The nuts should be field installed based on the existing motor bracket's hole pattern.

The inner pattern has (4) openings and uses 1/4-20 hardware. This configuration is typically used for the 230V operators, QKS16VF and IDD (330A or 400A controllers).

The outer pattern has (6) openings and uses 3/8-16 hardware. This configuration is typically used for the 115V operators, QKS16 (HX and 321A controllers). The top (2) openings are always used. Select the bottom set of holes based on the existing QKS16 mounting pattern.

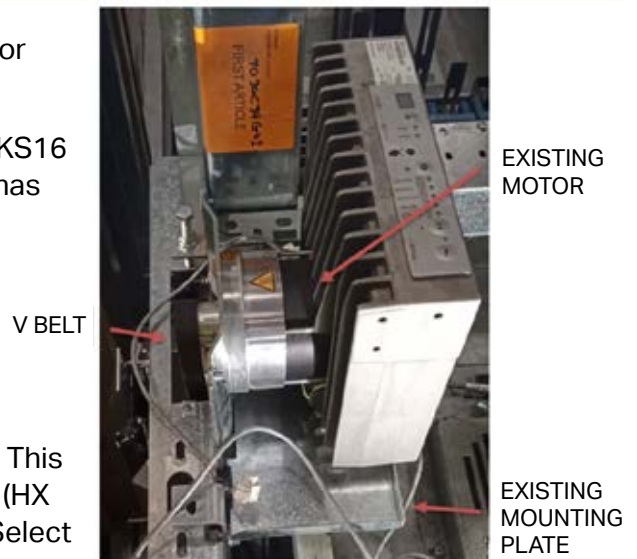

Figure 3: Existing IDD motor assembly

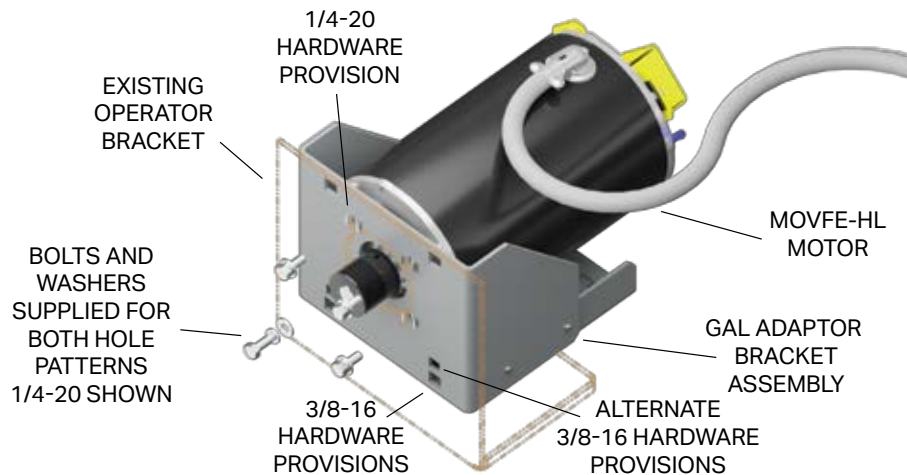

Figure 4. MOVFE-HL Motor Assembly

GAL CONVERSION KIT MOVFE-HL TO REPLACE EXISTING SEC QKS16 LINEAR AND IDD OPERATORS

Mount the limit control box with (4) 1/4" self-drilling screws to the crosshead. Four internal holes are pre-drilled into the box's base for mounting.

Adhesive cork is included for vibration dampening between the control box and its mounting surface.

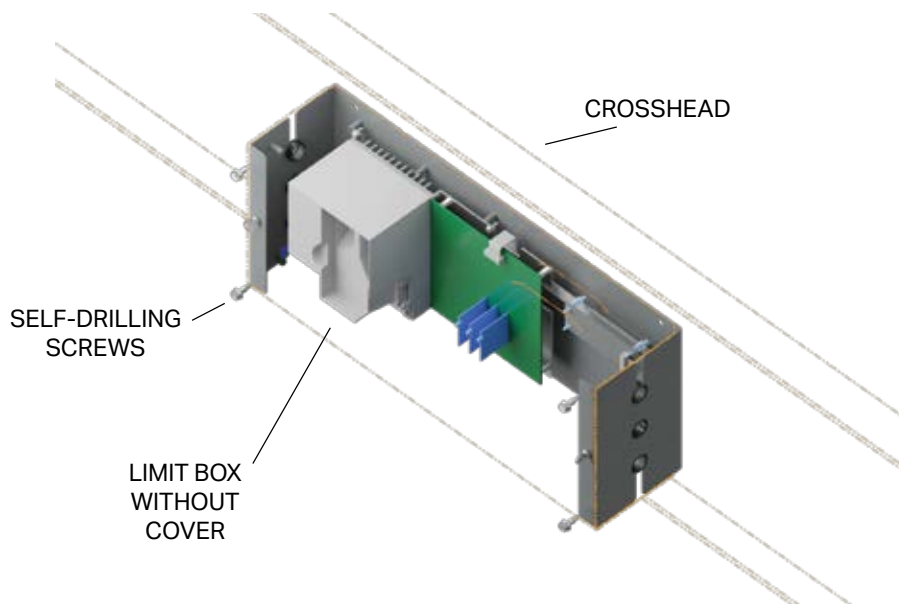

Figure 5: MOVFE-HL Drive Unit Box

2.4. SENSOR MOUNTING

The Sensor Bracket is designed to mount the MOVFE-HL sensors directly to the header. Self-drilling screws are provided to mount the bracket to the header. The activating magnet should be mounted to the outside of the existing gate switch roller bracket after the existing magnet is removed and top of the bracket cut off.

With the door closed, find a clear space on the header behind the gate switch bracket to mount the DCL sensor and bracket assembly. Make sure the header is also clear at the trailing edge for the DOL sensor and bracket assembly. See chart on the next page for the exact placement of the sensors. The calculated "X" dimension assumes a door lap of 1 1/4" for side slide doors.

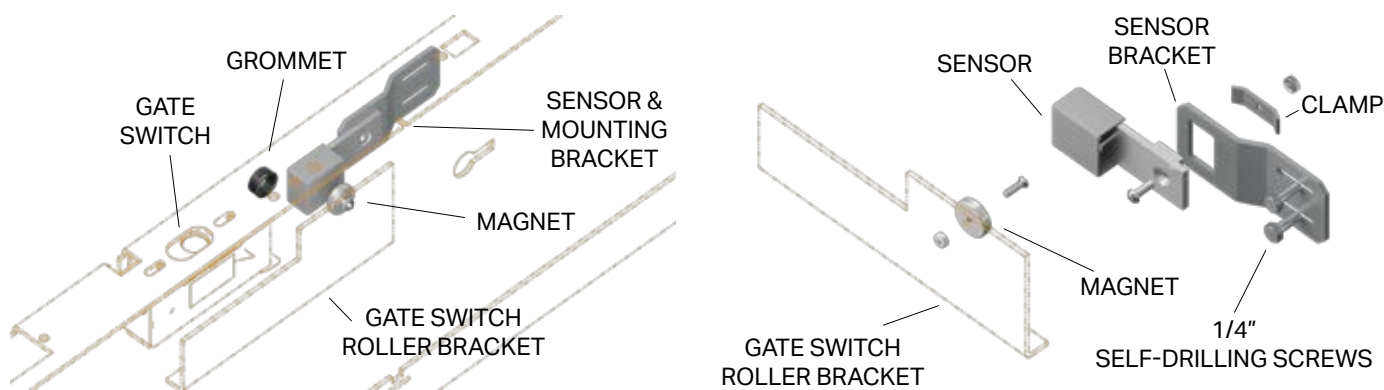

Figure 6: Sensor Bracket Mounting

GAL CONVERSION KIT MOVFE-HL TO REPLACE EXISTING SEC QKS16 LINEAR AND IDD OPERATORS

Two self-drilling 1/4" screws are provided to mount each sensor bracket to the header.

- Cut the top of the gate switch roller bracket off and remove the existing magnet.
- Drill a hole at the top, using a #7 drill bit. The hole should be centered on the face of the sensor when the door is fully closed.
- Secure the magnet to the outside of the bracket, facing the sensor, with the 8-32 hardware provided.

NOTE: Both sensors should face the same way and be horizontally in-line. The magnet should activate the sensor about 1/4" before full open/close.

Drill 7/8" holes next to the sensors and insert grommets. These holes allow the sensor wires to be fed back to the limit box. **NOTE: Be careful the hole does NOT interfere with existing components behind the header.**

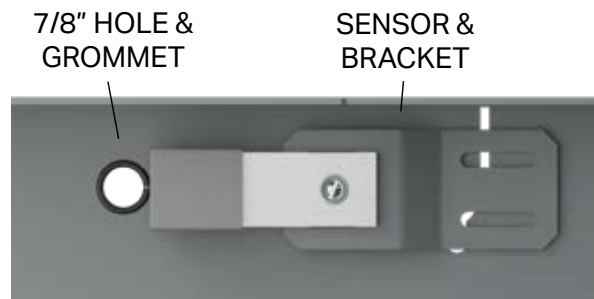

Figure 7: Sensor Bracket Position

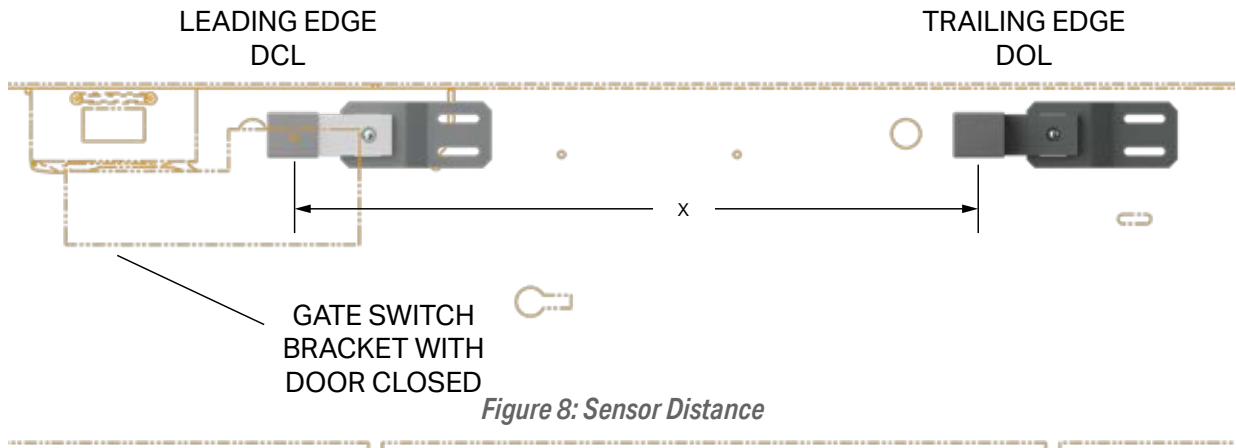

Figure 8: Sensor Distance

DOOR STYLE	COMMON OPENING WIDTHS	X (INCHES)	FORMULA FOR GENERIC X
Side Slide	36	37 1/4	Door Opening + Door Lap
	42	43 1/4	
	48	48 1/4	
Center Parting	42	21	1/2 Door Opening
	48	24	

2.5. FIELD WIRING DIAGRAM

The existing CIO board is located in the car operating panel. The existing encoder and line filter can be removed before rewiring to the new MOVFE board.

2.5.1. FOR QKS16VF AND IDD: ***230 VAC DRIVE ONLY***

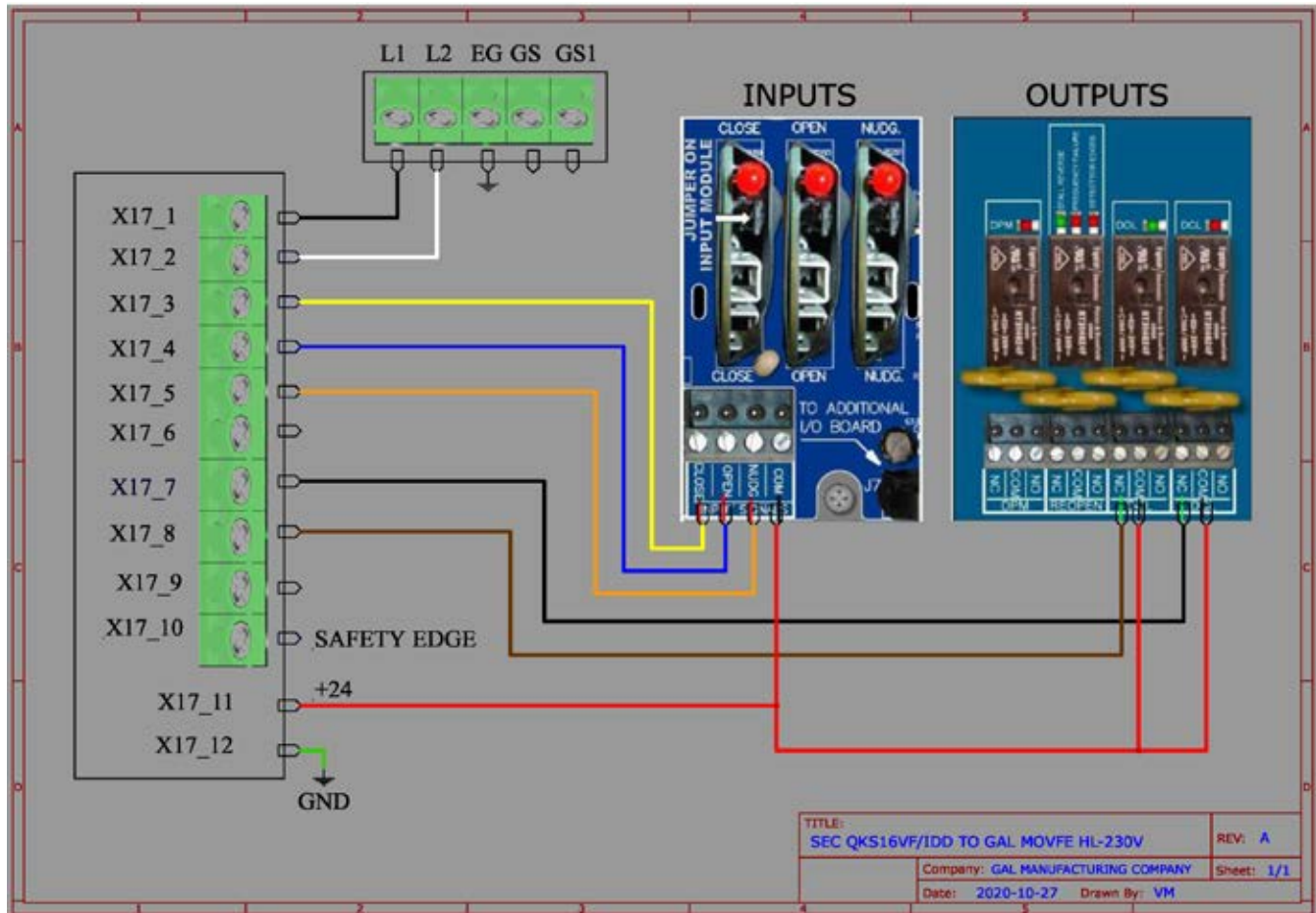

SIGNAL	CONTROLLER TERMINAL (EXISTING SEC)	OPERATOR TERMINAL (NEW GAL)	WIRE COLOR
Power +	.X17.1	L1	Black
Power -	.X17.2	L2	White
VST-S (close output)	.X17.3	CLOSE (input)	Yellow
VST-O (open output)	.X17.4	OPEN (input)	Blue
VRV-RT (nudging output)	.X17.5	NUDGING (input)	Orange
KET-S (DCL input)	.X17.7	DCL NC (output)	Black
KET-O (DOL input)	.X17.8	DOL NC (output)	Brown
+24 VDC	.X17.11	COM (input & output)	Red
GND	.X17.12	ENCLOSURE GNDv	Green

2.5.2. FOR QKS16: ***115 VAC DRIVE ONLY***

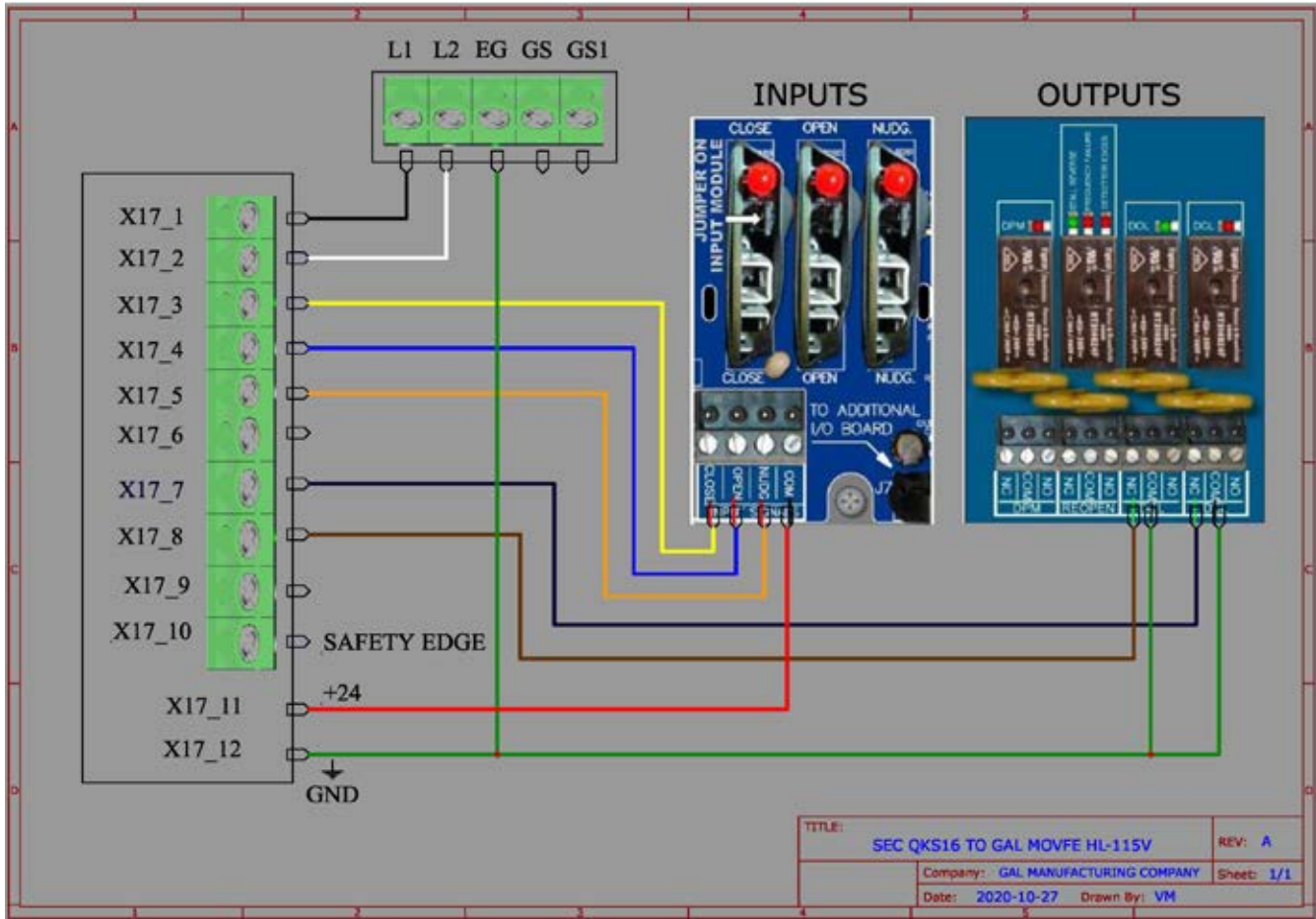

SIGNAL	CONTROLLER TERMINAL (EXISTING SEC)	OPERATOR TERMINAL (NEW GAL)	WIRE COLOR
Power +	.X17.1	L1	Black
Power -	.X17.2	L2	White
VST-S (close output)	.X17.3	CLOSE (input)	Yellow
VST-O (open output)	.X17.4	OPEN (input)	Blue
VRV-RT (nudging output)	.X17.5	NUDGING (input)	Orange
KET-S (DCL input)	.X17.7	DCL NC (output)	Black
KET-O (DOL input)	.X17.8	DOL NC (output)	Brown
+24 VDC	.X17.11	COM (input)	Red
GND	.X17.12	ENCLOSURE GND & COM (output)	Green

2.6. INITIAL ELECTRICAL SETUP

2.6.1. CONNECTIONS TO THE MAIN ELEVATOR CONTROLLER

Connect wires to the main elevator controller (See "Field Wiring Diagram").

The major connections are:

EARTH GROUND

115VAC or 230VAC between L1 & L2

DOL (Door Open Limit)

DCL (Door Close Limit)

CLOSE (Door Close)

OPEN (Door Open)

NUDG. (Nudging)

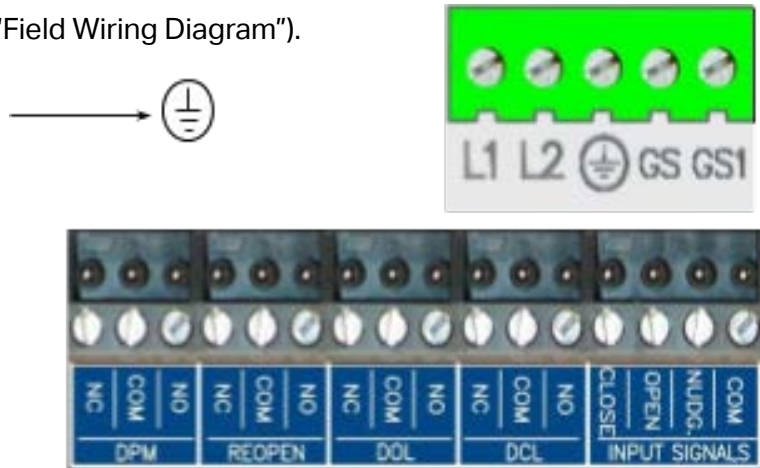

NOTE:

- Check the MOVFE-HL drives to apply 115VAC or 230VAC appropriately. Power Requirement: 1KVA, Slow-Blowing External Fuse Size: 8Amp for 230VAC & 16Amp for 115VAC.
- If the Input Voltage for OPEN, CLOSE, and NUDG are less than 60VAC or DC, jumpers on the top of the input modules of the MOVFE-HL drives must be removed.
- In automatic mode, the MOVFE-HL will only accept input signals from the elevator controller.
- REOPEN output relay is optional.

2.6.2. INITIAL SETUP

The following initial procedure is helpful for users, if needed. The initial procedure is to assure the following:

- The motor is in the correct direction.
- The encoder is in the correct direction.
- The correct default parameter set is downloaded (written) to the MOVFE-HL drive.
- The door width is learned.
- The operation source is selected.



1. Turn Power ON
2. Motor direction:
 - a. Run the door in Manual mode.
 - b. If the door closes and opens in the correct direction go to 3.
 - c. Otherwise swap any 2 of motor wires as shown, and test again.

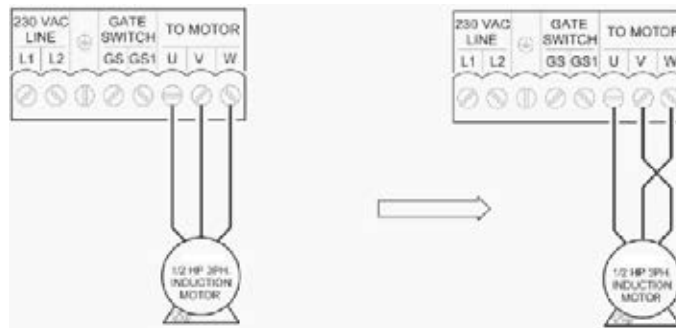

3. Encoder direction
 - a. Press . Run the door in Manual mode using the toggle switches.
 - b. If the door Closes and the counter Decreases, or the door Opens and the counter Increases, then the encoder Direction is Correct.
 - c. Otherwise, change parameter 42.



4. Encoder direction
 - a. Flip the RUN|SETUP switch to SETUP. Set Par. 63 = 1.
 - b. Flip the RUN|SETUP switch to RUN.
 - c. Use Manual mode to run the door from DOL to DCL, or vice versa.
 - d. Follow the prompts on the LCD display. LEARN DOOR WIDTH LED will flash and turn off when the learning process is completed. Par. 63 will set itself back to Zero.

2.7. LED INDICATORS

A red LED is provided on each of the input modules (Open, Close, or Nudge). Heavy and Narrow inputs are optional and require an additional I/O board, which will be provided on request to carry out the Heavier and Narrower door functions.

Note that if the input signals voltage is 60V or less, the jumpers on each input module must be removed.

There are 20 more LEDs, on the main board, to indicate the completion of the door width learning, the directions, the final limit positions, nudging, holding, dynamic slowdown distances, input signals, output signals, and voltage levels. The illustration below identifies those LEDs.

Voltage Levels:

- +24V
- +5V
- 15V
- +15V

CLOSE DIRECTION		OPEN DIRECTION	
CLOSE		OPEN	
NUDG.			
CLOSE SLOWDOWN		OPEN SLOWDOWN	
HOLDING		HOLDING	

FAULT(S)

ENCODER FAILED

SENSOR(S) FAILED

LEARN DOOR WIDTH

THE LED OF THE INPUT MODULE DRAWS CURRENT FROM THE ELEVATOR CONTROLLER, NOT FROM THE VFE-2500 DOOR OPERATOR. THE LED WILL BE LIT IF THE ELEVATOR CONTROLLER HAS SENT A COMMAND.

IF THE INPUT VOLTAGE FOR OPEN, CLOSE, AND NUDG. IS LESS THAN 60VAC OR DC, JUMPERS ON THE TOP OF THE INPUT MODULES MUST BE REMOVED.

Input Modules: DPM, STALL REVERSE, FREQUENCY FAILURE, DETECTOR EDGES, DOL, DCL.

Input Modules: CLOSE, OPEN, NUDG.

2.8. MOVFE-HL DRIVE

The MOVFE-HL drive is an integral part of the MOVFE-HL system. Velocity and distance feedbacks are combined to deliver precise and smooth stops at DOL or DCL every time.



MOVFE-HL drive provides the connections for:

- Single phase input power supply between L1 & L2 terminals.
 - Note: 230V +/-15V or 115V +/-15V, 50/60Hz, and minimum 500VA are required.
- Earth ground
 - Note: A True Earth Ground is required.
- Convenience Gate switch terminals: GS & GS1. Note! GS & GS1 are only convenience terminals. They have no internal connection to the MOVFE-HL.
- 3-phase induction motor on U, V, W terminals.



The connector is a pluggable type to ease the connection and swapping the drive. The RJ12 mating connector for the parameter unit is located on the MOVFE-HL drive.

The International Ground Symbol is the True Earth Ground that is connected to the system. A connector and a green screw, size 8/32 x 3/8, are provided by GAL as shown. Use position 22-14 of the crimping tool to crimp the wire into the connector and use the green screw to screw the ground connector to the chassis of the MOVFE-HL door operator. The following materials are recommended:

- A minimum # 14 AWG conductor size for Ground wire.
- Crimping tool made by SARGENT/USA.



2.9. PARAMETER UNIT

The Parameter Unit (P/N 2500-3051) is a tool that plugs into the MOVFE-HL drive and permits changing values of relevant parameters.

- Learning the door widths of the regular door and narrower door.
- Changing accelerations, decelerations, speeds, torques, and all pertinent parameters of peripheral devices. See the defaults parameters table for more details.
- Downloading (copying, reading), uploading (writing) to and from the drive.
- Storing all default sets of parameters and a reference working set of parameters.
- Monitoring currents, voltages, inputs, outputs, faults, encoder directions, closing time.
- Resetting the drive.

The following will describe in depth about the parameter unit:

2.9.1. HOW TO CHANGE PARAMETERS

- Press  . Enter a parameter number.
- Press  . Enter a new value. Press  . Wait for the Completed signal from the LCD display.

2.9.2. HOW TO READ (COPY) FROM A DRIVE

- Press  . Press 
- Press  . Wait for the Completed signal from the LCD display.

2.9.3. HOW TO WRITE (DOWNLOAD) TO A DRIVE

- Press  . Press 
- Press  . Wait for the Completed signal from the LCD display.

2.9.4. DEFAULT PARAMETERS

CLOSING	Pr.#	RANGE	DEFAULT VALUE					
			HARMONIC		LINEAR			
			C/P	S/O	STRAIGHT		GEARED	
				C/P	S/O	C/P	S/O	
MAX. CLOSE SPEED	136	0-60	30	30	30	30	30	30
HOLDING TORQUE	137	0-3	0.6	0.6	0.6	0.6	0.2	0.2
HOLDING SPEED	138	0-400	2	2	2	2	2	2
HOLDING BEGINS	139	0-100	3	3	2	2	2	2
CLOSE TORQUE ▲	140	0-400	243	173	270	270	100	120
HIGH SPD (HSC)	141	0-400	25	19	25	20	25	20
FINAL SPD (FSC)	142	0-400	5	5	3	2	4	5
FSC BEGINS	143	0-100	6	10	5	5	5	10
NUDGING SPD	144	0-400	15	9	10	15	15	15
ACCEL. TIME	145	0-360	4	6	6	6	6	2
DECEL. TIME	146	0-360	8	10	15	20	10	4
STALL REV. FORCE	148	0-4.5	1.6	2.0	1.4	1.4	0.6	0.9

OPENING	Pr.#	RANGE	DEFAULT VALUE					
			HARMONIC		LINEAR			
			C/P	S/O	STRAIGHT		GEARED	
				C/P	S/O	C/P	S/O	
QUICK STOP ON REV.	78	0-4.5	1.2	1.4	2.0	2.0	1.2	1.2
HOLDING TORQUE	79	0-3	0.6	0.6	0.6	0.6	0.2	0.2
HOLDING SPEED	80	0-400	2	2	2	2	2	2
HOLDING BEGINS	81	0-100	99	99	99	99	99	99
SLOW SPD (SSO)	82	0-400	5	5	3	5	3	5
CLUTCH ENG. DIST.	83	0-100	12	12	12	12	12	12
HIGH SPD (HSO)	84	0-400	31	45	45	45	45	50
FINAL SPD (FSO)	85	0-400	7	7	3	5	3	5
FSO BEGINS	86	0-100	95	95	98	98	90	95
ACCEL. TIME	87	0-360	6	4	6	4	4	2
DECEL. TIME	88	0-360	12	14	12	12	12	4
OPEN TORQUE ▲	89	0-400	120	120	80	80	80	100

▲ : TO LOWER TORQUE, INCREASE THE VALUE.

COMMON	Pr.#	RANGE	DEFAULT VALUE								
			HARMONIC			LINEAR					
			L	R	C/P	STRAIGHT			GEARED		
			L	R	C/P	L	R	C/P	L	R	C/P
SELECTION OF THE HAND OF THE DOOR <small>L = LEFT R = RIGHT C/P = CENTER PARTING</small>	42	1-2	2	1	2	1	2	1	2	1	2
CARRIER FREQ.	1	0-15	12								
SCAN FREQ.	61	0-400	9								
LEARNING FREQ.	62	0-400	9								
EDGES DELAY TIME	197	0-180	15								
EDGES HOLD TIME	206	0-180	5								
BUZZER DELAY TIME	198	0-180	10								
OVERLOAD	217	0-6	2.5								
BUZZER MODE	205	0-2	0: DISABLE 1: CONTINUOUS 2: PULSE								
DET. EDGES MODE	202	0-2	0: DISABLE 1:NPN 2: PNP								
NARROWER DOOR	199	0-1	0: ENABLE 1: DISABLE								
NARROWER DOOR DOL	204	0-1	0: USE BOTH DOL AND AUX 1: USE DOL								
RE-OPEN RELAY MODE	207	0-1	0: MAINTAIN 1: DISABLE WHEN EDGES RELAY ON								
CLUTCH DISTANCE UNIT	76	0-1	0: PERCENT 1: PULSES								
CODE DIST. REG / HVY	69	0-65535	1" FOR S/O, OR 2" FOR C/P FROM DCL								
CODE DIST. NARROW	70	0-65535	1" FOR S/O, OR 2" FOR C/P FROM DCL								
CAN NODE ID	246	7-8	FRONT DOOR = 7 REAR DOOR = 8								
DOORWIDTH LEARNING	63	0-1	0: DISABLE 1: ENABLE								

2.9.5. SLOW MODE PARAMETERS

GAL has preset parameters for "slow mode" to optimum levels. If customers need to adjust them, however, reference the graphs below for the adjustments of Slow Speeds & Torques.

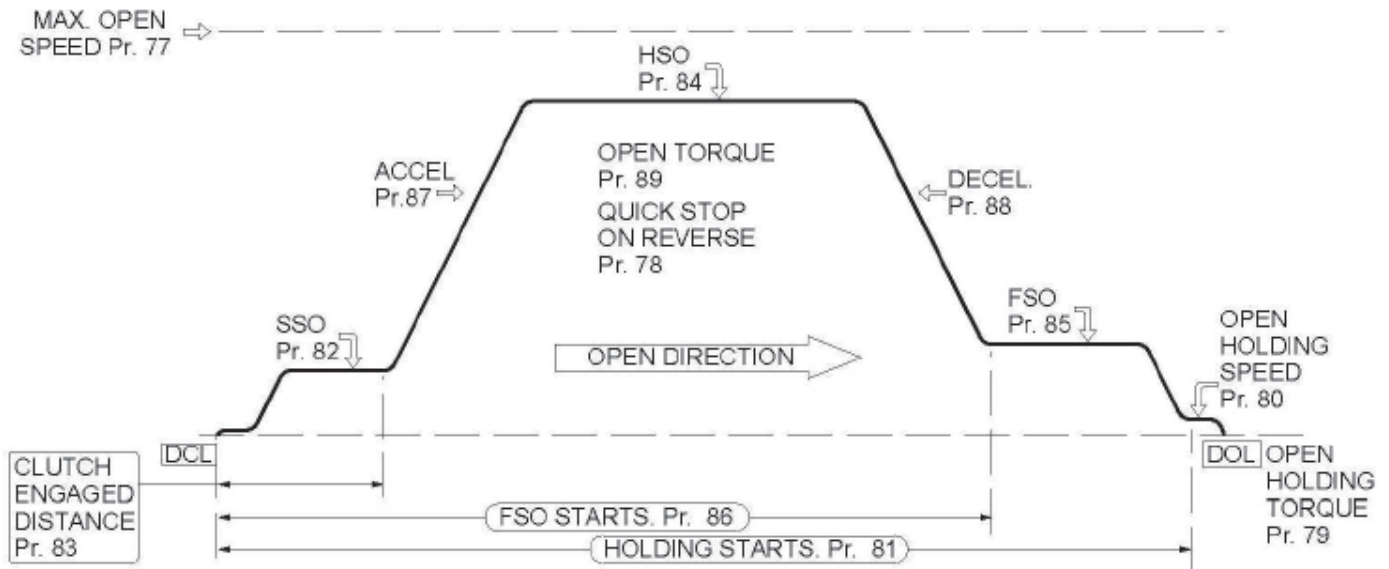

OPEN CYCLE GRAPH FOR NORMAL DOOR
FROM FINAL CLOSE TO FINAL OPEN

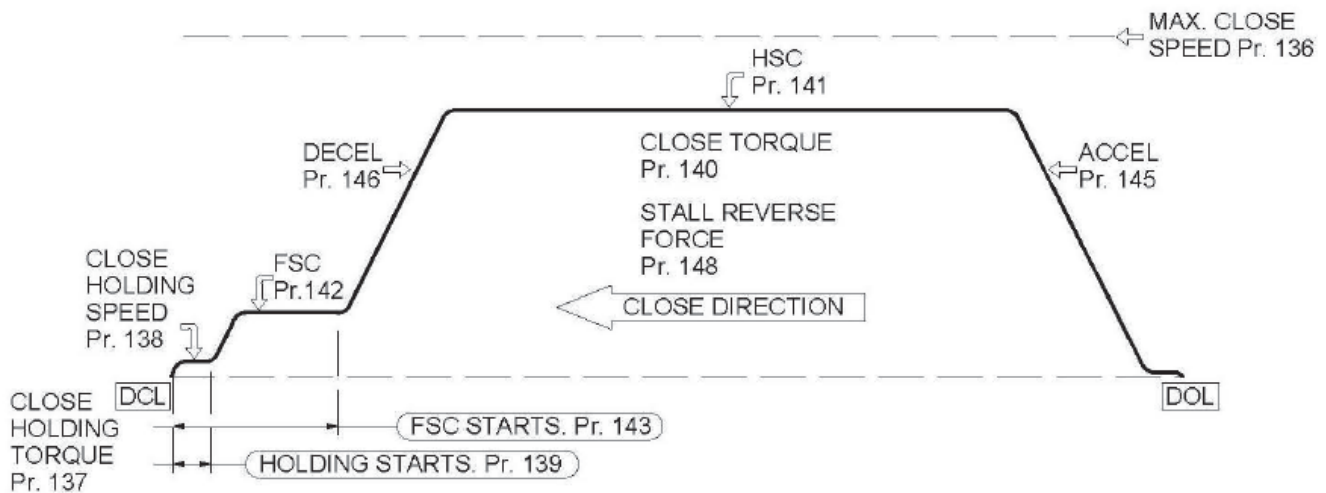

CLOSE CYCLE GRAPH FOR NORMAL DOOR
FROM FINAL OPEN TO FINAL CLOSE

2.9.6. CONVENIENCE KEYS

Press **SPEED** to display speeds in Hz.

Press **I/O** to display input and output signals.

Press **FAULT** to display recent faults.

Press  or  to view all recent faults.

Press **AMP** to display currents.

Press **RESET** to reset the drive.

2.9.7. LED INDICATORS

There are 7 LEDs on the Parameter Unit. DO, DC, NUD, HLD, PRG, FLT, and OVT. They have the following meanings:

- DO= Door Open.
- DC= Door Close.
- NUDG. = Nudging
- HLD= Holding.
- PRG= Programming Mode
- FLT= Fault
- OVT= Over Torque.

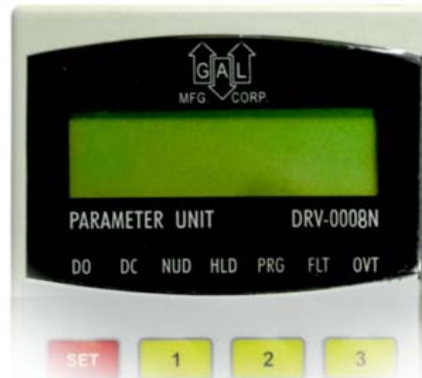

2.9.8.THE VIEW KEY

The **VIEW** key will help users navigate through the Parameter Unit seamlessly.

Press **VIEW** then press  or  to navigate all items under the VIEW section.

Once the desired item is found, press **READ** to view an item.

Press **ESC** at any time to get back to the previous display.

The following items are under the **VIEW** key:

2.9.8.1. VOLTAGE, CURRENT, COMMAND FREQUENCY AND ACTUAL FREQUENCY (HZ)



2.9.8.2. INPUTS & OUTPUTS MONITORING

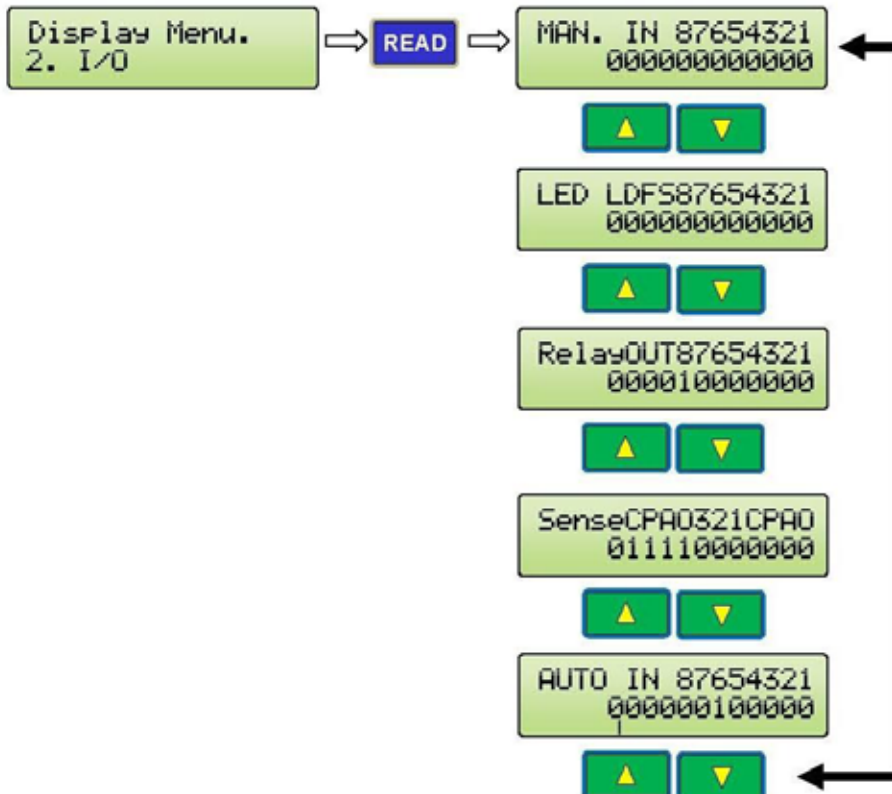

2.9.8.3. FAULTS

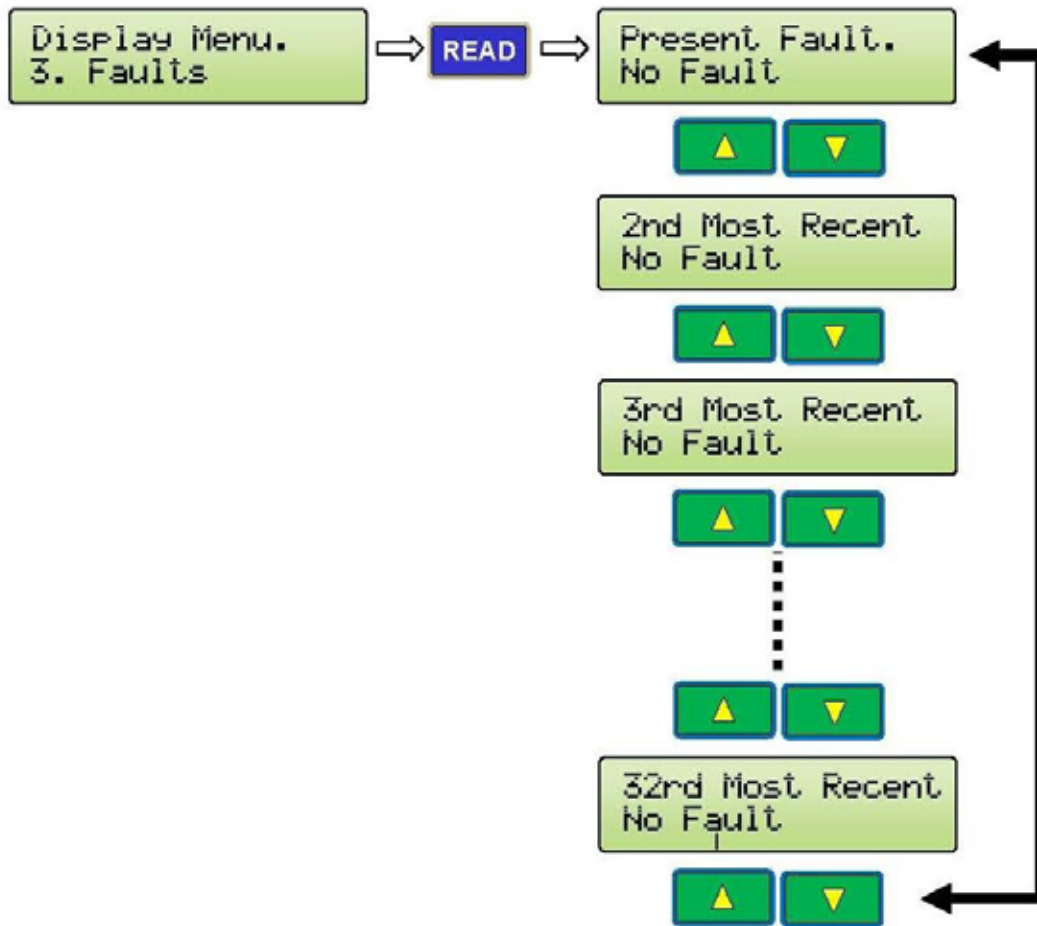

2.9.8.4. COUNTERS

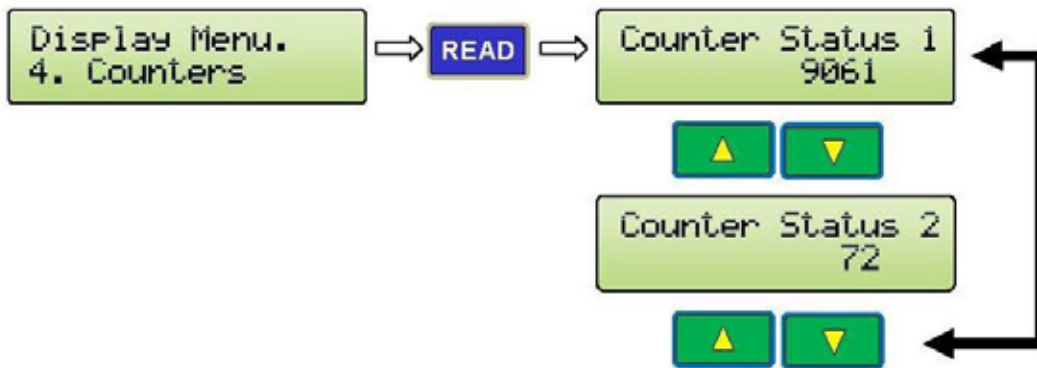

2.9.8.5. DIGITAL I/O PARAMETERS

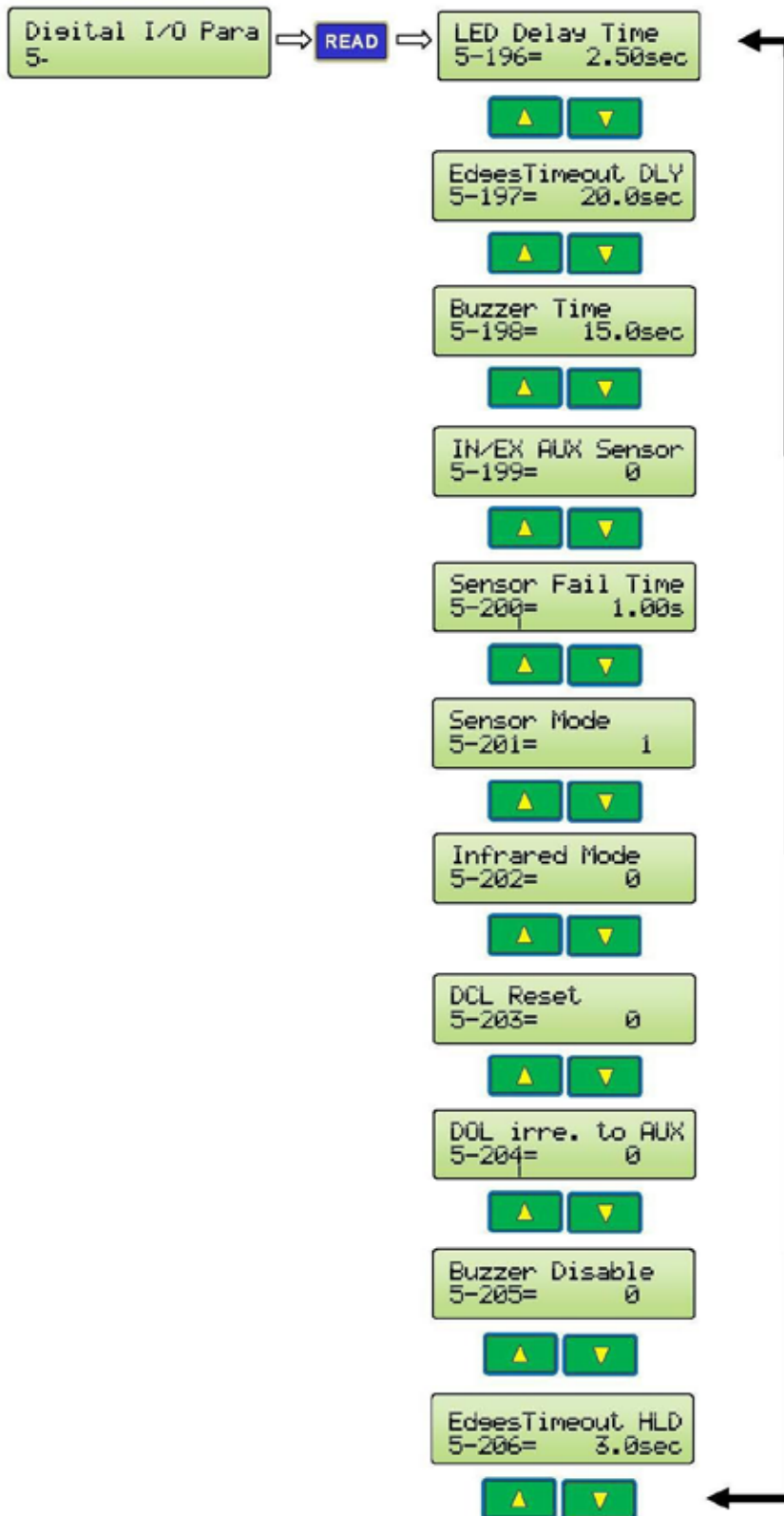

2.9.8.6. DIRECTION

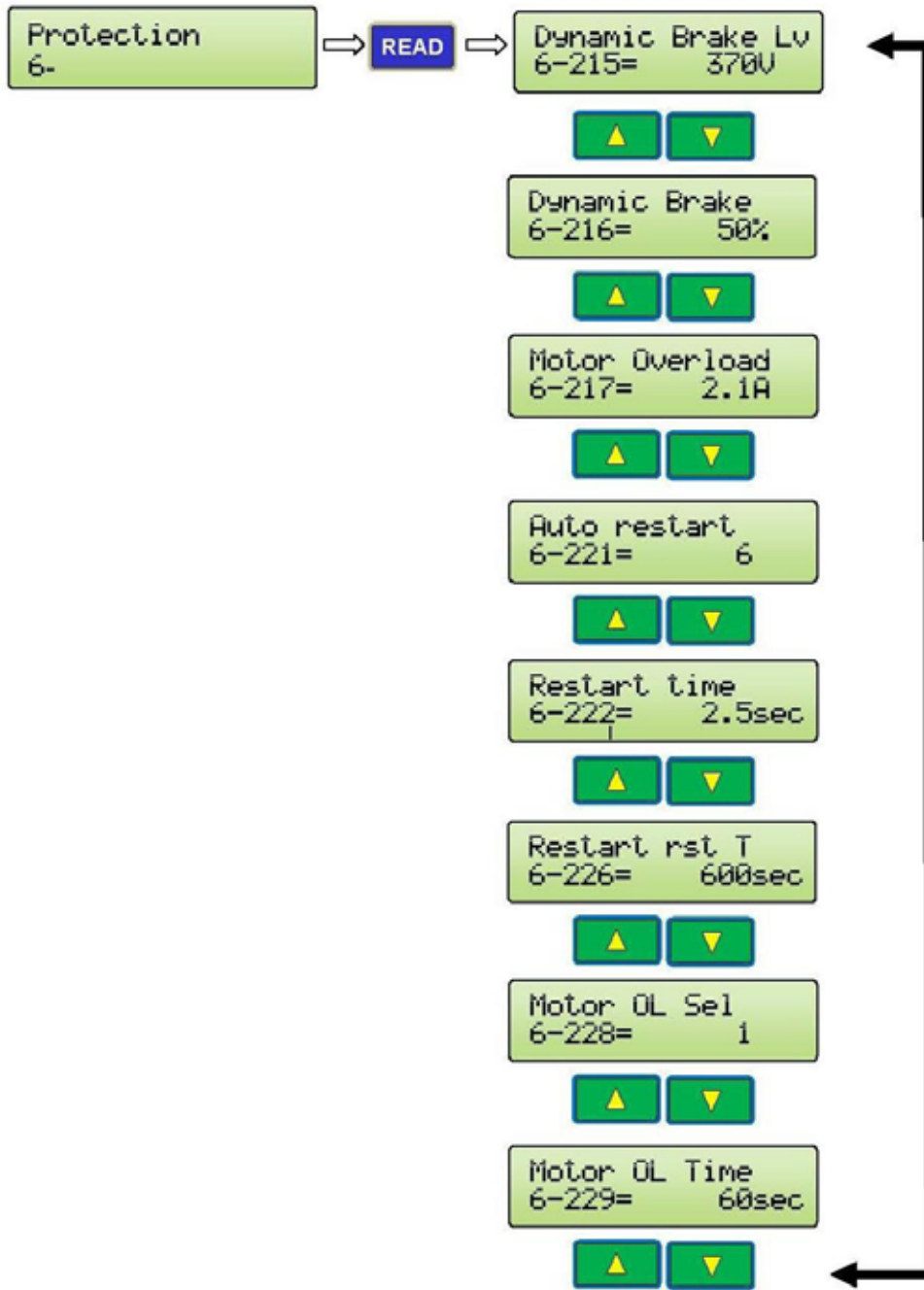

2.9.8.7. COMMUNICATION

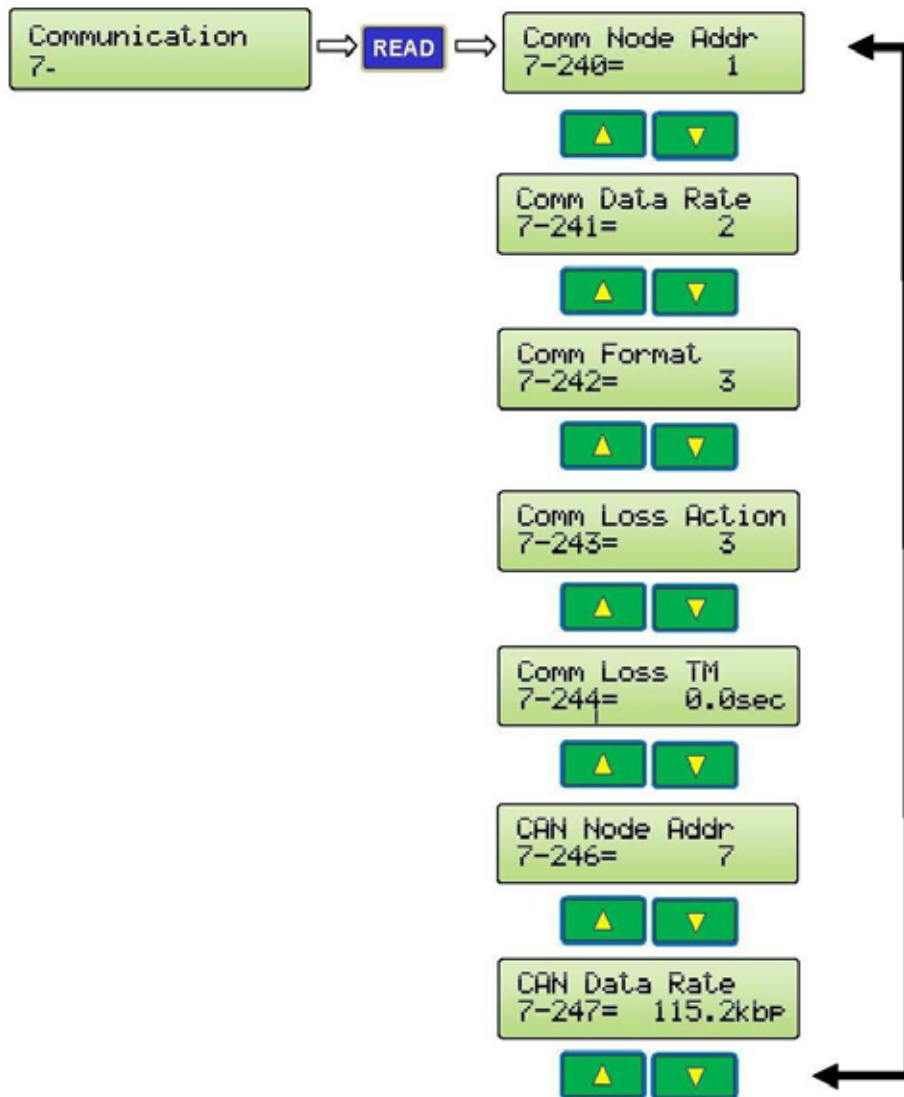

2.9.8.8. MAXIMUM CLOSE SPEED



2.9.8.9. MAXIMUM CLOSE FORCE



2.9.8.10. G.A.L. DEFAULT PARAMETER SETS

- HARMONIC (REFERENCE ONLY)
- LINEAR STRAIGHT (ONLY SET USED FOR QKS16 APPLICATION)
- LINEAR GEARED (REFERENCE ONLY)

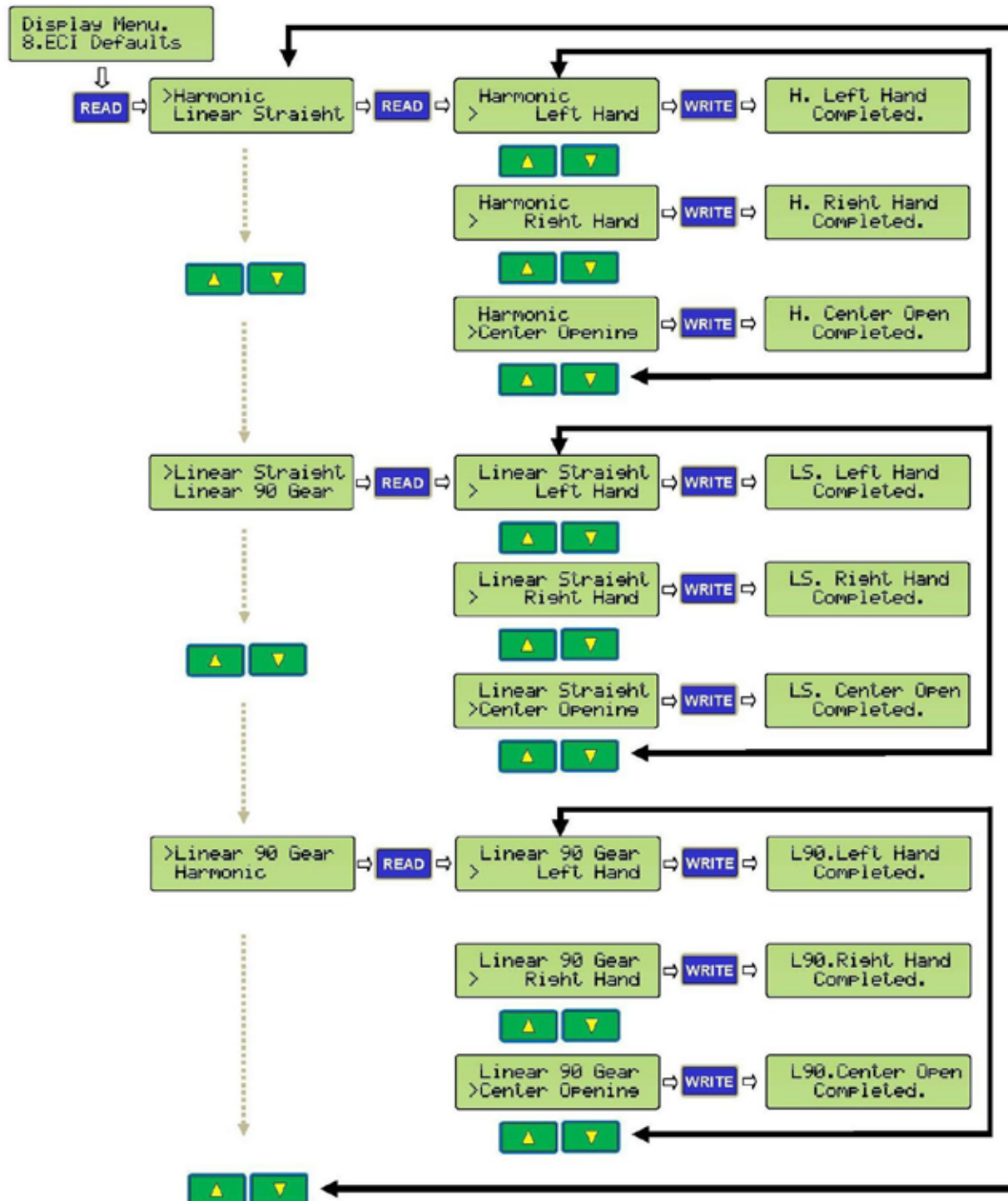

2.9.8.11. DISPLAY GROUPS FOR MONITORING AND TROUBLESHOOTING

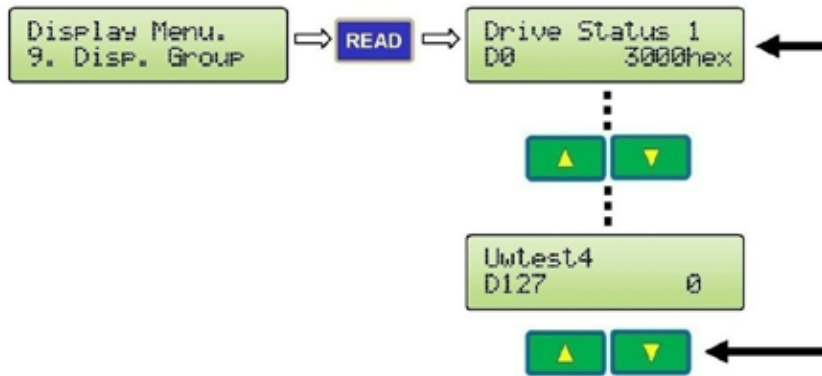

2.9.8.12. CODE DISTANCE CLOSING TIME DISPLAY

- CD CLOSING TIME
- DOL - DCL TIME
- CD OPENING TIME
- DCL - DOL TIME

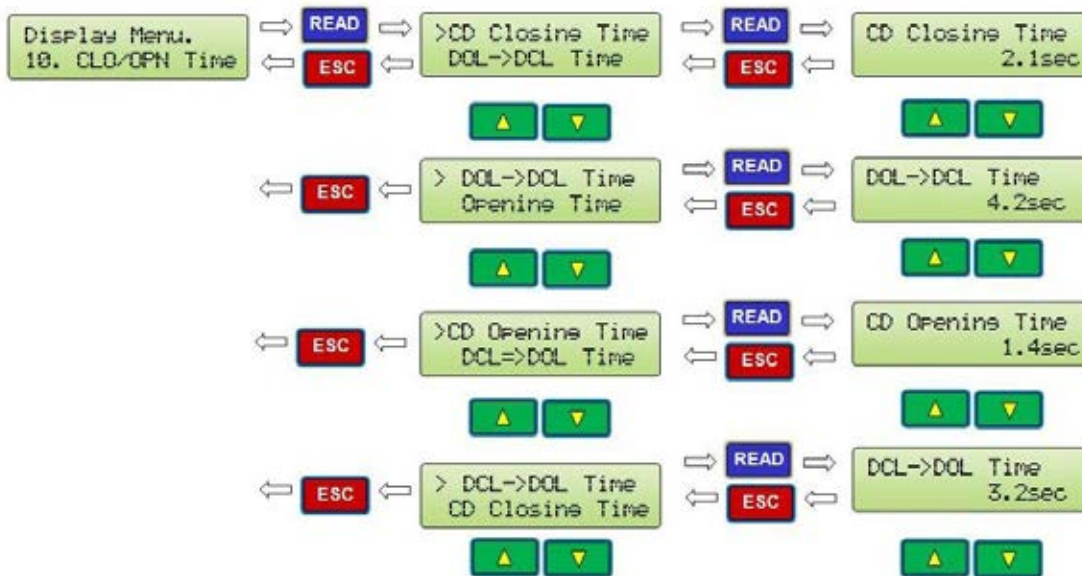

2.9.8.13. CAN ANALYZER

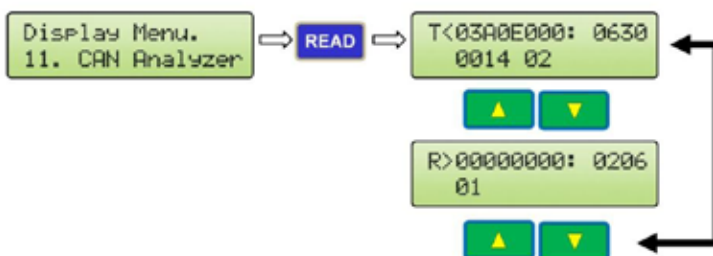

3. FAULTS LIST

Fault Display	Meaning	Reset	Auto Reset	Record	Drive Response	Reset Condition
Over-current	Over-current	Yes	Yes	Yes	Coast to Stop	Continuous current must be less than 50% of rated current for 5 seconds
Remedy	<ol style="list-style-type: none"> 1. Check the wiring connections to U, V, W for possible short circuits. 2. Check the wiring connections between the AC motor drive and motor for possible short circuits, also to ground. 3. Check for loose contacts between AC motor drive and motor. 4. Increase the acceleration time. 5. Check for possible excessive loading conditions at the motor. 6. If there are still any abnormal conditions when operating the AC motor drive after a short-circuit is removed and the other points above are checked, it should be sent back to manufacturer. 					

Fault Display	Meaning	Reset	Auto Reset	Record	Drive Response	Reset Condition
Over-voltage	Over-voltage	Yes	Yes	Yes	Coast to Stop	DC-bus must be less than 385V for 230V Drive
Remedy	<ol style="list-style-type: none"> 1. Check if the input voltage is over the rated voltage of the 2500-3050 drive input voltage range. 2. Check for possible voltage transients. 3. DC-bus over-voltage may also be caused by motor regeneration. 4. Increase the deceleration time . 5. Check whether the required braking power is within the specified limits. 6. Check for proper earth ground wire. 					

Fault Display	Meaning	Reset	Auto Reset	Record	Drive Response	Reset Condition
Over heat	Over heat	Yes	Yes	Yes	Coast to Stop	Heatsink temperature must be less than 161°F (71.6°C)
Remedy	<ol style="list-style-type: none"> 1. Ensure that the ambient temperature falls within the specified temperature range. 2. Remove any foreign objects from the heatsink and check for possible dirty heat sink fins. 					

Fault Display	Meaning	Reset	Auto Reset	Record	Drive Response	Reset Condition
Drive Overload	Drive Overload	Yes	Yes	Yes	Coast to Stop	Continuous current must be less than 50% of rated current for 5 seconds
Remedy	<ol style="list-style-type: none"> 1. Check whether the motor is overloaded. 2. Reduce torque 					

Fault Display	Meaning	Reset	Auto Reset	Record	Drive Response	Reset Condition
Motor Overload	Motor Overload	Yes	Yes	Yes	Coast to Stop	Continuous current must be less than 50% of rated current for 5 seconds
Remedy	<ol style="list-style-type: none"> 1. Reduce the motor load 2. Check, remove any foreign objects preventing the motor from moving. 3. Repair defective mechanical system. 					

GAL CONVERSION KIT MOVFE-HL TO REPLACE EXISTING SEC QKS16 LINEAR AND IDD OPERATORS

Fault Display	Meaning	Reset	Auto Reset	Record	Drive Response	Reset Condition
Hardware Failure	Hardware protection failure	No	No	Yes	Coast to Stop	
Remedy	Return to GAL					

Fault Display	Meaning	Reset	Auto Reset	Record	Drive Response	Reset Condition
OC at Accel	Over current during Acceleration	Yes	Yes	Yes	Coast to Stop	Continuous current must be less than 50% of rated current for 5 seconds
Remedy	1. Short-circuit at motor output: Check for possible poor insulation at the output lines. 2. Torque boost too high: Decrease the torque compensation setting in Pr.33. 3. Acceleration Time too short: Increase the Acceleration Time.					

Fault Display	Meaning	Reset	Auto Reset	Record	Drive Response	Reset Condition
OC at Decel	Over current during Deceleration	Yes	Yes	Yes	Coast to Stop	Continuous current must be less than 50% of rated current for 5 seconds
Remedy	1. Short-circuit at motor output: Check for possible poor insulation at the output line. 2. Deceleration Time too short: Increase the Deceleration Time.					

Fault Display	Meaning	Reset	Auto Reset	Record	Drive Response	Reset Condition
OC At Steady	Over current during steady state operation	Yes	Yes	Yes	Coast to Stop	Continuous current must be less than 50% of rated current for 5 seconds
Remedy	1. Short-circuit at motor output: Check for possible poor insulation at the output line. 2. Sudden increase in motor loading: Check for possible motor stall.					

Fault Display	Meaning	Reset	Auto Reset	Record	Drive Response	Reset Condition
Ground Fault	Short to ground	No	No	Yes	Coast to Stop	Continuous current must be less than 50% of rated current for 5 seconds
Remedy	When one of the output terminals is grounded, short circuit current is more than 1.5A, the AC motor drive power module may be damaged. 1. Check whether the IGBT power module is damaged. 2. Check for possible poor insulation at the output line. NOTE! The short circuit protection is provided for AC motor drive protection, not for protection of the user.					

Fault Display	Meaning	Reset	Auto Reset	Record	Drive Response	Reset Condition
EEPROM Read Fail	CPU Read Failure	Yes	No	Yes	Coast to Stop	Immediately
Remedy	Return to factory					

Fault Display	Meaning	Reset	Auto Reset	Record	Drive Response	Reset Condition
Parameter Chksum	CPU WRITE Failure	Yes	No	Yes	Coast to Stop	Immediately
Remedy	Return to factory					

Fault Display	Meaning	Reset	Auto Reset	Record	Drive Response	Reset Condition
Comm Loss	Comm. Time out	Yes	No	Yes	Disable Coast to Stop Ram to Stop Warning	Immediately
Remedy	<ol style="list-style-type: none"> 1. Check the RS485 connection between the AC motor drive and RS485 master for loose wires and wiring to correct pins. 2. Check if the communication protocol, address, transmission speed, etc. are properly set. 3. Use the correct checksum calculation. 					

Fault Display	Meaning	Reset	Auto Reset	Record	Drive Response	Reset Condition
Autotune Failure	Auto-learning Error	Yes	No	Yes	Coast to Stop	Immediately
Remedy	<ol style="list-style-type: none"> 1. Check the cable between drive and motor 2. Retry again 					

Fault Display	Meaning	Reset	Auto Reset	Record	Drive Response	Reset Condition
Encoder Loss	Encoder Loss Error	Yes	Yes	Yes	Coast to Stop Ramp to Stop Warning & Scan Speed	Detect the correct signals of the Encoder
Remedy	Check the wiring of the encoder					

GAL CONVERSION KIT MOVFE-HL TO REPLACE EXISTING SEC QKS16 LINEAR AND IDD OPERATORS

Fault Display	Meaning	Reset	Auto Reset	Record	Drive Response	Reset Condition
Encoder Fbk Error	Encoder Direction Error	Yes	Yes	Yes	Coast to Stop Ramp to Stop Warning & Scan Speed	Movement direction is in agreement with the encoder direction defined by the drive.
Remedy	1. Check value of Par. 41. 2. Check if the wiring of the Encoder is correct.					

Fault Display	Meaning	Reset	Auto Reset	Record	Drive Response	Reset Condition
AUX Sensor Fail	AUX Error	Yes	Yes	Yes	Warning & Scan Speed	Recover if the signal is detected appropriately
Remedy	1. Check the AUX sensor 2. Check the wirings of the AUX sensor. 3. Check the Magnet for the Linear model.					

Fault Display	Meaning	Reset	Auto Reset	Record	Drive Response	Reset Condition
DPM Sensor Fail	DPM Error	Yes	Yes	Yes	Warning & Scan Speed	Recover if the signal is detected appropriately
Remedy	1. Check the DPM sensor 2. Check the wirings of DPM sensor. 3. Check the Magnet for the Linear model. 4. Check the Cam for the Harmonic model.					

Fault Display	Meaning	Reset	Auto Reset	Record	Drive Response	Reset Condition
DOL Sensor Fail	DOL Error	Yes	Yes	Yes	Warning & Scan Speed	Recover if the signal is detected appropriately
Remedy	1. Check the DOL sensor 2. Check the wirings of the DOL sensor. 3. Check the Magnet for the Linear model.					

Fault Display	Meaning	Reset	Auto Reset	Record	Drive Response	Reset Condition
DCL Sensor Fail	DCL Error	Yes	Yes	Yes	Warning & Scan Speed	Recover if the signal is detected appropriately
Remedy	1. Check the DCL sensor 2. Check the wirings of the DCL sensor. 3. Check the Magnet for the Linear model.					

4. KINETIC ENERGY AND ASME A17.1 2000

Requirement 2.13.4.2.4 of ASME A17.1 2000 stipulates that a data tag must be attached to the door operator or car crosshead. If you are in a jurisdiction that has adopted the 2000 code, you need to read and understand this requirement, and all the related requirements.

The data tag is required to show:

- The minimum closing code time for the door system that will result in average kinetic energy of less than 7.37 foot-pounds.
- The minimum code closing time for the door system, when in nudging, that will result in average kinetic energy of less than 2.5 foot-pounds.

The attached data tables are designed to give GAL customers the information necessary to comply with these requirements. If you use all GAL equipment, and follow GAL instructions, these sheets will give you the minimum closing code time for the normal door configurations and sizes originally available for the QKS16 operator.

4.1. CODE CLOSING DISTANCE / TIME

On side opening, the code distance starts 2" from the jamb and goes to 2" from full close. (opening size – 4")
On center opening, code distance starts 1" from the jamb and goes to 1" from full close. (still opening size – 4")
Times shown are minimums for the code closing distance.

4.2. AVERAGE KINETIC ENERGY (7.37 FT LBS)

This is the requirement for which the times shown on the data tables were calculated. The rotational inertia of the motor and operator is included in these calculations. GAL's calculations include equipment rigidly connected thereto and accommodate all hangers, rollers, clutches, closers, releases, and any normal reopening devices.

4.3. ACTUAL (PEAK) KINETIC ENERGY (17 FT LBS)

Using GAL equipment and following GAL instructions, you will not exceed the requirement for actual (peak) KE.

4.4. NUDGING KINETIC ENERGY (2.5 FT LBS)

If taking the minimum closing code time for your application and doubling it, you will have a safe time to use for the requirement under nudging. (Note – this is a very conservative time, if you want to close your door more quickly while in nudging, call GAL for an absolute minimum).

Paragraphs are excerpted from ASME 17.1 2000. They are provided here for your convenience only.

4.5. NON-STANDARD SYSTEMS

A non-standard application, like panels that are so heavy or light that they fall outside the range shown on the data tables, you can call GAL and we will calculate closing code time for your job. The following paragraphs are excerpted from ASME 17.1 2000. They are provided here for your convenience only.

2.13.4.2.4 Data Plate. A data plate conforming to 2.16.3.3 shall be attached to the power door operator or to the car crosshead and shall contain the following information:

- a. Minimum door closing time in seconds for the doors to travel the code zone distance as specified in 2.13.4.2.2 corresponding to the kinetic energy limits specified in 2.13.4.2.1(b)(2);
- b. Minimum door closing time in seconds for the doors to travel the Code zone distance as specified in 2.13.4.2.2 corresponding to the kinetic energy limits specified in 2.13.4.2.1(c)(2), if applicable [see 2.27.3.1.6(e)];
- c. Where heavier hoistway doors are used at certain floors, the minimum door closing time in seconds corresponding to the kinetic energy limits specified in 2.13.4.2.1(b)(2) and 2.13.4.2.1(c)(2), if applicable, for the corresponding floors shall be included on the data plate.

2.13.4.2.1 Kinetic Energy

- a. Where the hoistway door and the car door/gate are closed in such a manner that stopping either one manually will stop both, the kinetic energy of the closing door system shall be based upon the sum of the hoistway and the car door weights, as well as all parts rigidly connected thereto, including the rotational inertia effects of the door operator and the connecting transmission to the door panels.
- b. Where a reopening device conforming to 2.13.5 is used, the closing door system shall conform to the following requirements.
 1. The kinetic energy computed for the actual closing speed at any point in the Code zone distance defined by 2.13.4.2.2 shall not exceed 23 J (17 ft-lbf); and
 2. The kinetic energy computed for the average closing speed as determined in accordance with 2.13.4.2.2 shall not exceed 10 J (7.37 ft-lbf).
- c. Where a reopening device is not used, or has been rendered inoperative (see 2.13.5), the closing door system shall conform to the following requirements:
 1. The kinetic energy computed for the actual closing speed at any point in the code zone distance defined by 2.13.4.2.2 shall not exceed 8 J (6 ft-lbf).
 2. The kinetic energy computed for the average closing speed within the code zone distance (see 2.13.4.2.2), or in any exposed opening width, including the last increment of door travel, shall not exceed 3.5 J (2.5 ft-lbf).

NOTE:

The term "Door Weight" in the tables refers to the combined weight of all doors, including all car door (s) and all hoistway door(s) (of one floor only).

Also, note that if the weight of the hoistway door(s) varies by floor, different settings of the code distance closing time must be used from the table.

The following tables show the minimum closing code time for MOVFE-HL doors:

SINGLE SPEED SIDE SLIDING DOOR						
DOOR WIDTH (IN)	DOOR WEIGHT (LBS)	APPROX. EQUIPMENT WEIGHT (LBS)	CODE DISTANCE (IN)	AVERAGE KINETIC ENERGY (FT-LBS)	MINIMUM CODE TIME (SECONDS)	MINIMUM CODE TIME WHEN DOOR PROTECTION DISABLED (NUDGING) (SECONDS)
36	275	39	32	7.37	2.48	4.25
	300	39	32	7.37	2.56	4.38
	325	39	32	7.37	2.63	4.50
	350	39	32	7.37	2.70	4.62
	375	39	32	7.37	2.77	4.74
	400	39	32	7.37	2.84	4.85
	425	39	32	7.37	2.90	4.96
	450	39	32	7.37	2.97	5.07
42	325	39	38	7.37	3.12	5.34
	350	39	38	7.37	3.21	5.49
	375	39	38	7.37	3.29	5.63
	400	39	38	7.37	3.37	5.76
	425	39	38	7.37	3.45	5.89
	450	39	38	7.37	3.52	6.02
	475	39	38	7.37	3.60	6.15
	500	39	38	7.37	3.67	6.27

GAL CONVERSION KIT MOVFE-HL TO REPLACE EXISTING SEC QKS16 LINEAR AND IDD OPERATORS

TWO SPEED SIDE SLIDING DOORS						
DOOR WIDTH (IN)	DOOR WEIGHT (LBS)	APPROX. EQUIPMENT WEIGHT (LBS)	CODE DISTANCE (IN)	AVERAGE KINETIC ENERGY (FT-LBS)	MINIMUM CODE TIME (SECONDS)	MINIMUM CODE TIME WHEN DOOR PROTECTION DISABLED (NUDGING) (SECONDS)
48	375	50	44	7.37	3.29	5.63
	400	50	44	7.37	3.36	5.74
	425	50	44	7.37	3.42	5.85
	450	50	44	7.37	3.49	5.96
	475	50	44	7.37	3.55	6.07
	500	50	44	7.37	3.61	6.18
	525	50	44	7.37	3.67	6.28
	550	50	44	7.37	3.73	6.38

SINGLE SPEED CENTER PARTING DOOR						
DOOR WIDTH (IN)	DOOR WEIGHT (LBS)	APPROX. EQUIPMENT WEIGHT (LBS)	CODE DISTANCE PER SIDE (IN)	AVERAGE KINETIC ENERGY (FT-LBS)	MINIMUM CODE TIME (SECONDS)	MINIMUM CODE TIME WHEN DOOR PROTECTION DISABLED (NUDGING) (SECONDS)
42	325	50	19	7.37	1.58	2.70
	350	50	19	7.37	1.62	2.77
	375	50	19	7.37	1.66	2.84
	400	50	19	7.37	1.70	2.91
	425	50	19	7.37	1.74	2.98
	450	50	19	7.37	1.78	3.04
	475	50	19	7.37	1.81	3.10
	500	50	19	7.37	1.85	3.16
48	375	50	22	7.37	1.92	3.29
	400	50	22	7.37	1.97	3.37
	425	50	22	7.37	2.01	3.45
	450	50	22	7.37	2.06	3.52
	475	50	22	7.37	2.10	3.59
	500	50	22	7.37	2.14	3.66
	525	50	22	7.37	2.18	3.73
	550	50	22	7.37	2.22	3.80