

Conversion Kit: Dover Hatch Unistrut to GAL Track

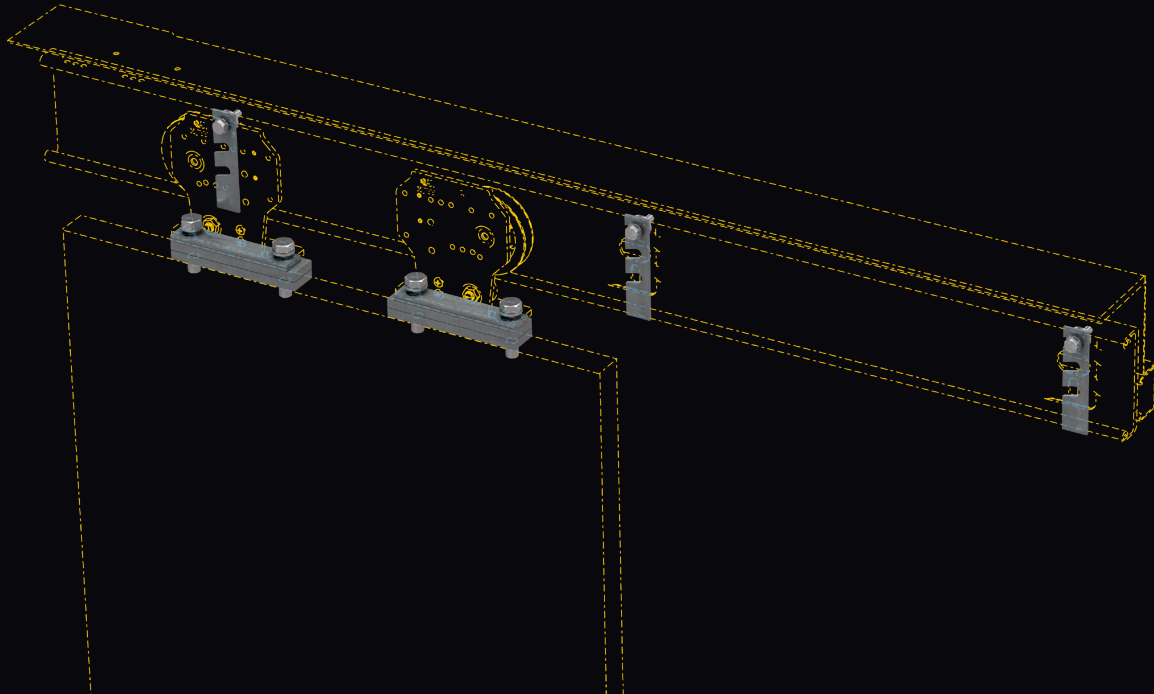

PRE-ENGINEERED GAL CONVERSION KIT

Adapts Dover Unistrut Hatch Header Style for GAL "A" Tracks

For many years GAL has offered custom-made solutions to adapt existing Dover Hatch Unistrut to mount GAL tracks. These modernizations are typically tricky because the unistrut is welded to the hatch header and cannot be easily removed, plus it's difficult and time consuming to survey the existing conditions. Now, we've generalized this kit to work for all Dover Hatch Unistrut applications with added instructions.

This kit provides all additional parts needed for a track installation. Customers only need to order (1) part number per opening to receive all necessary components.

BENEFITS

- Includes everything needed to convert the door equipment to GAL parts (Hanger assembly ordered separately)
 - Hanger adaptors, spacers, and longer bolts
 - Track spacers and additional bolts
- Dimensions range
 - Single Speed: Up to 48" opening
 - Two Speed: Up to 72" opening
 - Center Parting: Up to 59" opening
- Available for center parting, single speed, and two speed
- Easy to convert. Special surveys not necessary
- Used with GAL's "A" series of hatch tracks
- Only 1 part number per landing



MODERNIZATION KITS

KIT05-2001N - Dover Unistrut to GAL A Track Kit - Single Speed

KIT05-2002N - Dover Unistrut to GAL A Track Kit - Center Parting / Two Speed

CONTENTS OF EACH KIT

Sheave Mounting Hardware

KIT05-2001N: QTY 1
KIT05-2002N: QTY 2

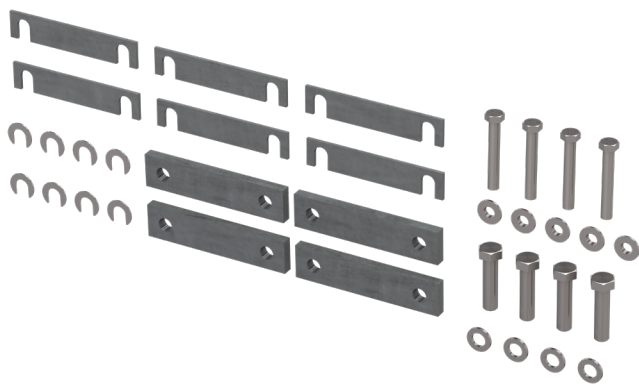

Track Spacers and Mounting Hardware



**INSTALLATION
MANUAL**



A VANTAGE Company

50 E. 153rd St.
Bronx, NY 10451-2104
Ph: 718.292.9000
Fax: 718.292.2034

info@gal.com
www.gal.com
sales@vantageelevation.com
www.vantageelevation.com

VANTAGE
THE POWER TO MOVE
REGIONAL SERVICE CENTERS

Chicago	877.300.5830
New York	917.336.4597
Miami	877.241.9354
L.A.	877.300.5816
Dallas	469.706.9316
Toronto	888.425.2262