

## THE NEXT GENERATION OF LINEAR DOOR OPERATORS

Streamlines and simplifies installation by integrating the operator directly onto the header

Quick delivery, ideally suited for new installations

### BENEFITS

- Reduced installation time as all components are header and track mounted
- Drop-in, low profile 9 in. (22.9 cm) header reduces weight by 40%
- Versatile configurations to satisfy most requirements
- CSA B44/ASME A17.1 approved
- Accommodates a range of door-to-door clearances from close coupled to standard 3.7-5.5 in. (9.4-13.9 cm)
- 1200 lbs total panel weight capacity
- Features integral Car Door Interlock, eliminating the need for fascia

### FEATURES

- Automatic 'smart' functions:
  - Calculates and optimizes open and close drive cycles
  - Learns door opening and adjusts speeds to meet kinetic energy requirements
- Integrated Car Door Interlock (no zone lock, no gate switch, no costly fascia)
- Equipment ships assembled to the car header ready to install
- Compatible with standard GAL templates and door drillings
- Motor encoder detects door position. No limit switches to wire in
- Wide range of communications interfaces including USB and GAL CAN
- Speeds ~ 2.5 ft/s
- For use with Single Speed, Two Speed, Center Parting, and Two Speed Center Parting door types

## ELECTRICAL SPECIFICATIONS

POWER SUPPLY	MOTOR	INPUTS	OUTPUTS
AC Voltage range: 120/230VAC Frequency supply: 50/60Hz	Pancake, Direct Drive Power: 1/2 HP	Universal inputs (accepts control signals in form of dry contacts or signal voltages from 24V to 230V, AC or DC)	Dry Contacts Serial GAL CAN

### MOnext® EQUIPMENT

### MOnext® HATCH EQUIPMENT

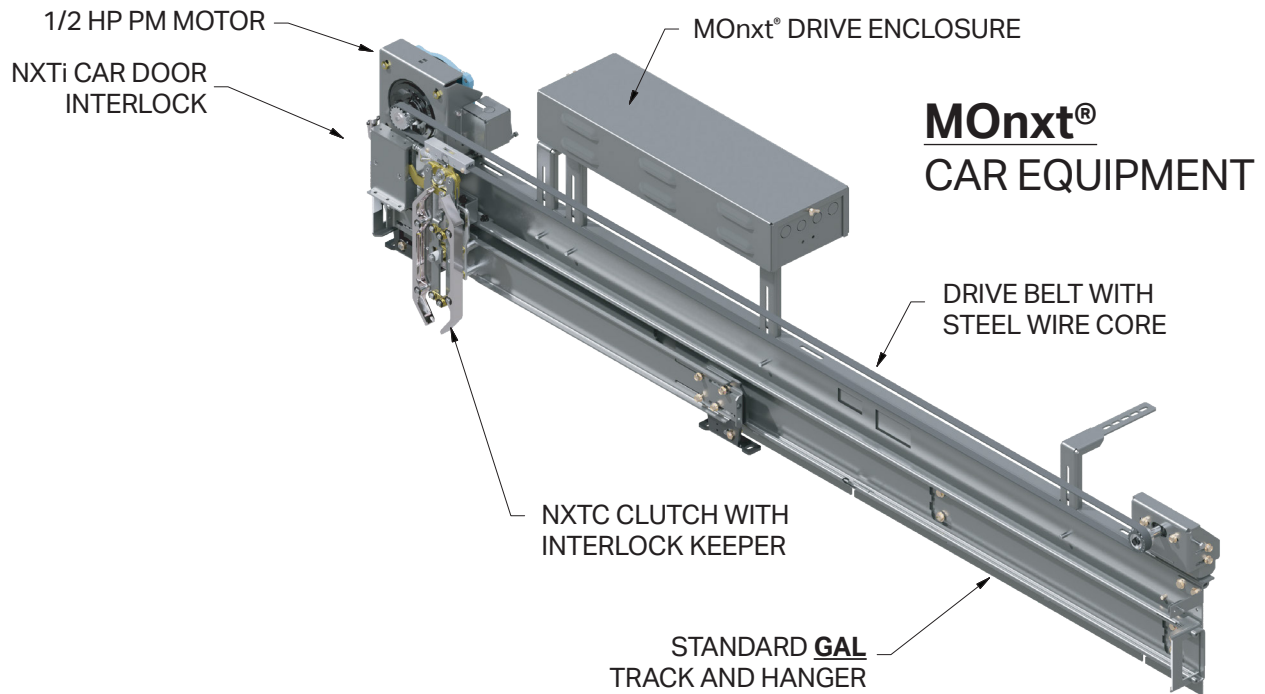
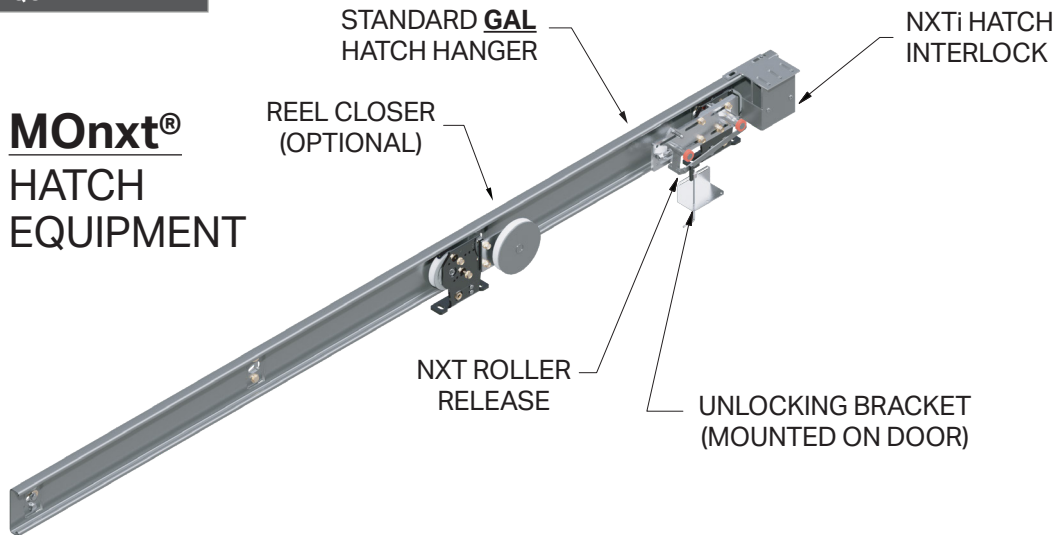

50 E. 153rd St.  
Bronx, NY 10451-2104  
Ph: 718.292.9000  
Fax: 718.292.2034

info@gal.com  
www.gal.com  
sales@vantageelevation.com  
www.vantageelevation.com



Chicago 877.300.5830  
New York 917.336.4597  
Miami 877.241.9354  
L.A. 877.300.5816  
Dallas 469.706.9316  
Toronto 888.425.2262