

# MOVFR<sup>3</sup> Door Operator

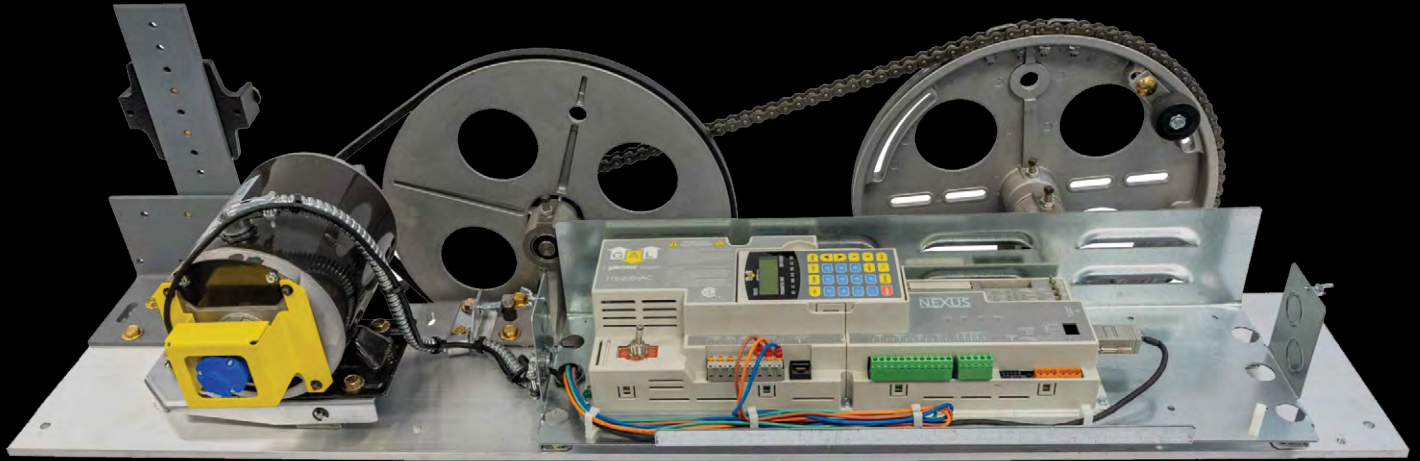

## INSTALLATION & ADJUSTMENT MANUAL

---

DOC-0171N  
02/2025



50 E. 153rd St.  
Bronx, NY 10451-2104  
Ph: 718.292.9000  
Fax: 718.292.2034

info@gal.com  
www.gal.com  
sales@vantageelevation.com  
www.vantageelevation.com



Chicago	877.300.5830
New York	917.336.4597
Miami	877.241.9354
L.A.	877.300.5816
Dallas	469.706.9316
Toronto	888.425.2262

## Comments

All G.A.L. door operators are factory adjusted and tested for the actual job requirements. When installed correctly, they may require minor adjustments to suit actual job conditions.

## Important Note

All equipment must be installed, adjusted, tested, and maintained to comply with all Federal, State, and Local codes. See section 8.5, page 29 in this manual for Kinetic Energy and closing force requirements. Before mounting the operator, check that the car door is plumb, free, and moves easily without binding. Check the attached standard measurements sheets in Section 7. Install the operator according to these measurements.

## Foreword

It is the intent of this manual to give the reader certain key points of information critical to the proper installation of the door operator. It is not intended to give comprehensive installation procedures nor does it cover the installation of door headers, tracks, hangers, etc. It is hoped that the procedures presented in this manual will reduce the installation and adjustment time and result in a smooth, long-lasting door operation. When properly installed, G.A.L. operators will provide many years of trouble-free service.

Copyright © 2025, G.A.L. Manufacturing Corporation, All rights reserved.

No part of this document may be reproduced in any form, machine or natural, without the express written consent of G.A.L Manufacturing Corporation.



# CONTENTS

<b>COMMENTS</b>	<b>1</b>
<b>IMPORTANT NOTE</b>	<b>1</b>
<b>FOREWORD</b>	<b>1</b>
<b>MOVFR<sup>3</sup> MECHANICAL ADJUSTMENTS</b>	<b>4</b>
<b>1. MOVFR<sup>3</sup> OPERATORS</b>	<b>5</b>
<b>2. DETERMINING THE HAND OF THE DOOR</b>	<b>6</b>
<b>3. MOUNTING THE OPERATOR</b>	<b>7</b>
<b>4. PRE-ADJUSTMENT TIP</b>	<b>8</b>
<b>5. ADJUSTING SIDE SLIDE DOORS - SINGLE SPEED AND TWO SPEED</b>	<b>9</b>
5.1. CRANK ARM AND CLUTCH LINK POSITIONS WITH DOOR CLOSED	<b>9</b>
5.2. CRANK ARM AND CLUTCH LINK POSITIONS WITH DOOR OPEN	<b>10</b>
<b>6. ADJUSTING CENTER PARTING CAR DOORS</b>	<b>11</b>
6.1. CRANK ARM AND CLUTCH LINK POSITIONS WITH DOOR CLOSED	<b>11</b>
6.2. CRANK ARM AND CLUTCH LINK POSITIONS WITH DOORS OPEN	<b>12</b>
<b>7. OPERATOR DATA TABLES FOR SIDE SLIDE AND CENTER PARTING DOORS</b>	<b>13</b>
<b>MOVFR<sup>3</sup> ELECTRICAL ADJUSTMENTS</b>	<b>16</b>
<b>8. ELECTRICAL ADJUSTMENTS</b>	<b>17</b>
8.1. OVERVIEW	<b>17</b>
8.2. THE NEXUS DRIVE	<b>17</b>
8.3. INITIAL SETUP	<b>24</b>
8.4. THE NEXUS PARAMETER UNIT	<b>25</b>
8.5. PARAMETER ADJUSTMENTS	<b>29</b>
8.6. SPEED PROFILES OF THE MOVFR <sup>3</sup>	<b>31</b>
8.7. HEAVY DOOR APPLICATION	<b>32</b>
8.8. DOOR STALL FORCE MEASUREMENT	<b>33</b>
8.9. HOW TO REPLACE THE DRIVE	<b>34</b>
<b>9. PARAMETER LIST</b>	<b>35</b>
<b>10. TROUBLESHOOTING GUIDE</b>	<b>41</b>

# **MOVFR<sup>3</sup>**

## **MECHANICAL ADJUSTMENTS**

## 1. MOVFR<sup>3</sup> OPERATORS

The MOVFR<sup>3</sup> door operator utilizes a 1/2 HP AC motor. The controls include the AC motor, encoder, and VVVF drive. The illustrations on this page show the three different versions available (Left-Hand, Right-Hand and Center-Parting) and the clearance envelopes.

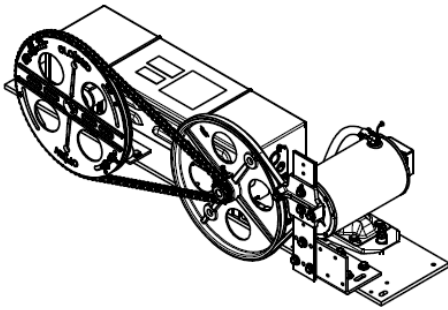

Left Hand Side Opening

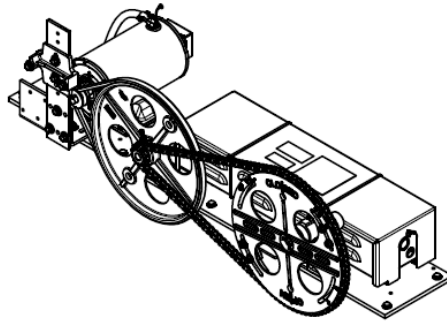

Right Hand Side Opening

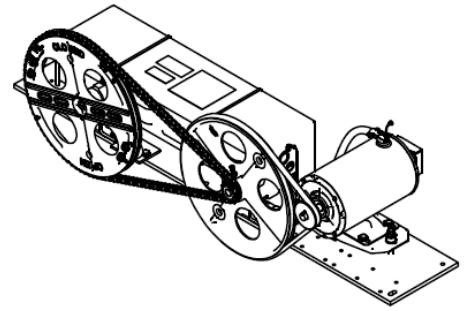

Center Parting Opening

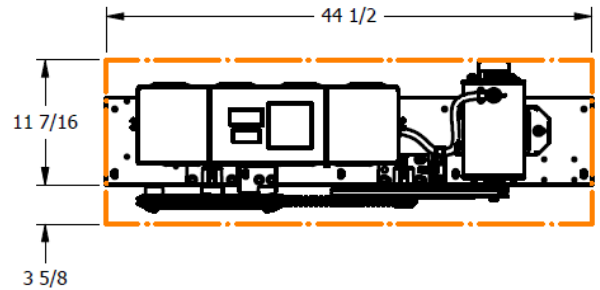
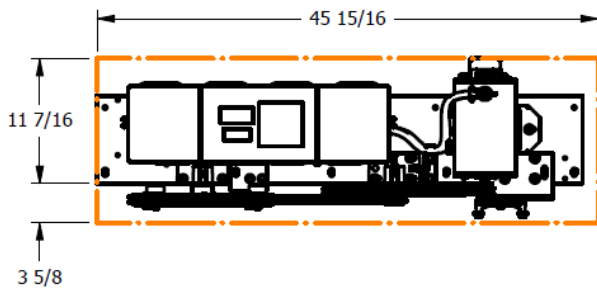

DOOR OPENING GREATER THAN 44" ( $10.5 < "R" < 13.125$ )  
NEW DRIVE ARM ASSEMBLY OP24-0002N  
IS NEEDED, AND ENVELOPE INCREASES TO 15 13/16

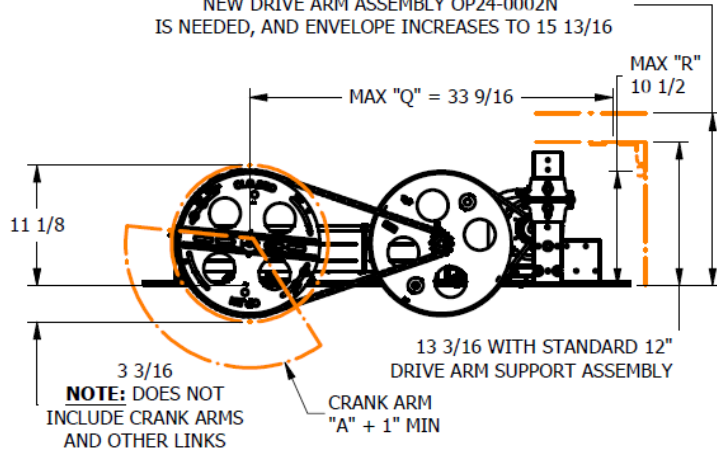

Left Hand Envelope

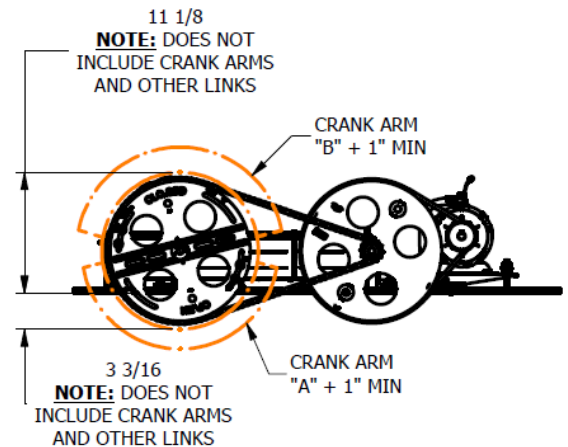

Center Parting Envelope

## 2. DETERMINING THE HAND OF THE DOOR

G.A.L. door operators are available for left and right-hand doors (center parting doors use a variation of the left-hand operator). To determine the hand of the door, stand in the lobby facing the elevator doors. If the door closes to the left, it is a left-hand door. If the door closes to the right, it is a right-hand door.

To swap hands in the field, see

[https://www.gal.com/wp-content/uploads/2019/05/MOVFR\\_Hand\\_Swap\\_Procedures.pdf](https://www.gal.com/wp-content/uploads/2019/05/MOVFR_Hand_Swap_Procedures.pdf)

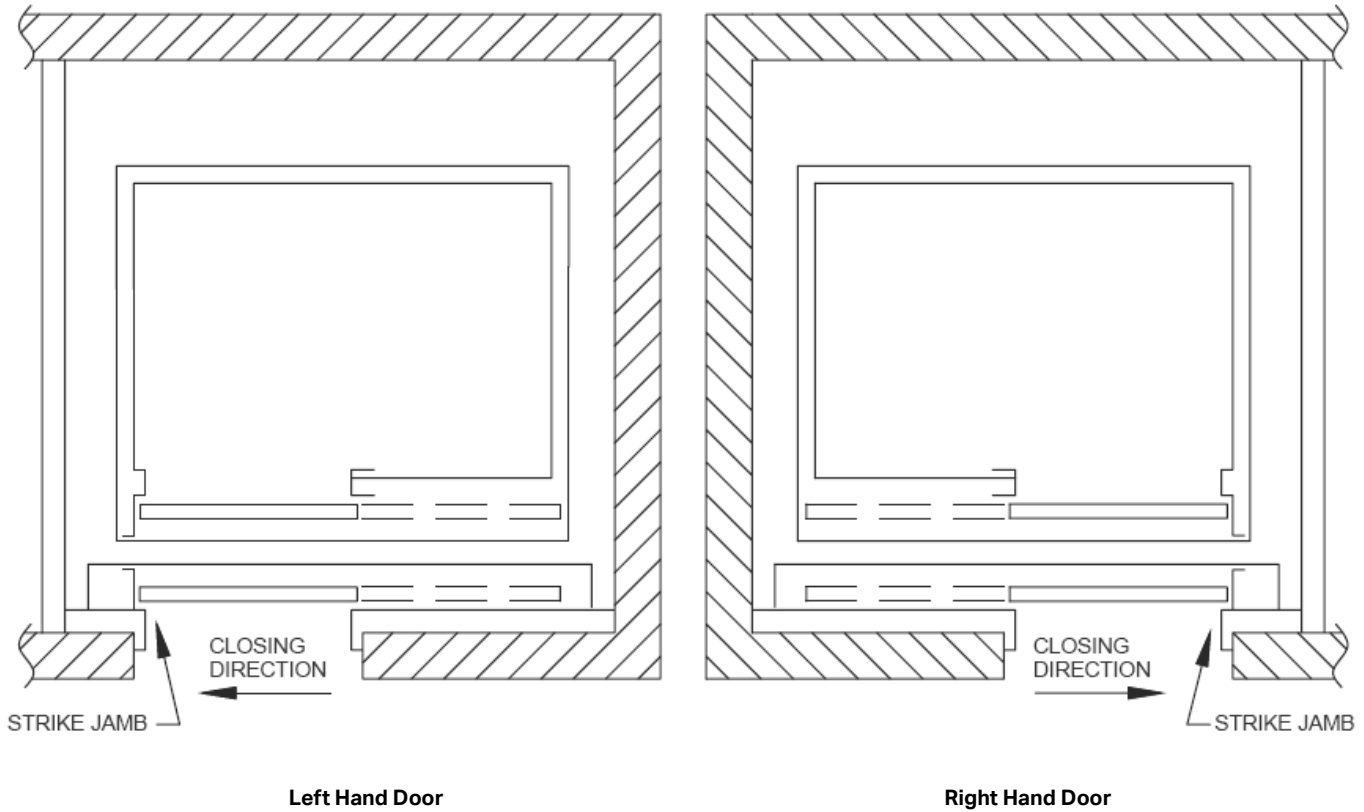

### 3. MOUNTING THE OPERATOR

As with all G.A.L. operators, it is important to have the proper mechanical set up. Before continuing, check that doors are hung properly and glide freely with no binding. The spring closer should also be set so that the hoistway door will close fully on its own. The door operator should be mounted in the proper position with the drive arm plumb and the drive links and pivots set according to the data tables, which can be found at <https://www.gal.com/products/door-equipment/operators/>. Slight differences are acceptable.

#### **Install the isolation pads:**

Isolation pads for the operator base are provided to minimize noise and vibration transmission into the cab. These pads must be adhered to the operator base before mounting it to the car top.

#### **Set the header plumb:**

Place the operator over the pre-tapped holes in the header assembly. Set the base flush with the face of the header assembly and tighten the front bolts only. Move the operator base and header until the header is perfectly plumb. Temporarily clamp the rear of the base to the operator support to prevent any further movement of the header.

#### **Side opening doors:**

With the header assembly correctly installed, the vertical centerline of the operator drive pulley should be 9 3/4" from daylight for a door opening of 22" to 44" and 14 3/4" for a door opening of 45" to 48" (see Figure 2).

#### **Center parting doors:**

With the header assembly correctly installed, the center of the door opening lines up with the center of the header track. The center of the operator drive pulley should also line up with center of the opening (see Figure 5).

#### **Determining the position of the front edge of the door operator base:**

Mount the drive arms to the drive arm support brackets on the header assembly for center parting doors and to the drive arm support bracket for side slide doors. The mounting brackets are slotted for fine adjustment later, if needed. At this time, position the arms in the center of the bracket and tighten it.

Attach the clutch assembly to the drive door linkage, and then attach the clutch to the drive door using the pre-tapped holes or key-slots on the door panel. Tighten the clutch assembly to the drive door. Attach the other door (for center parting doors) to its linkage and tighten the door bracket to the center of the slots.

Attach the connecting linkage(s) to the drive pulley, making sure that when the word "CLOSED" is on top, the doors will be closed. Tighten the linkage(s) to drive pulley.

Raise or lower the rear operator support bracket mounted to the cab to vertically level the operator drive pulley. This helps to prevent binds in the opening and closing.

Check that the operator arms hang free and are not forced to or away from the operator drive pulley. Slide the operator forward or backward, if necessary. Turn the drive pulley by hand, making sure that the drive arms and connecting links are made in parallel planes to the door and track. If necessary, slide the operator base forward or backward.

Proper positioning of the operator is critical to the life of the arm bearings. Bending of the drive arms will place stress on the bearings, reducing their operating life.

Once the operator base is in correct position, drill the holes to permanently fasten the rear of the operator and tighten all mounting bolts.

## 4. PRE-ADJUSTMENT TIP

### BEFORE PROCEEDING TO THE ADJUSTMENT SECTIONS, READ THE FOLLOWING TIPS (REFER TO FIGURE 1)

**Note:** The stop rollers are factory set and should not be adjusted. Make sure that in both directions the operator stops against the stop roller and the operator links and bearings are not under stress.

For easier setup during installation do not mount door restricting components until operator adjustments are made. Think of the drive pulley crank arm(s) and the connecting link(s) as each having its own function.

The crank arm determines the total door travel. The further the arm is away from the drive pulley centerline, the further the door travels.

The connecting link determines the door position. The longer the arm, the further the door is from the jamb.

**Example:**

The door opening is 42" but the door travels only 40" as stopped by the open and close stop rollers.

To correct the under travel, when in the full open position extend the connecting link from the drive pulley to move the door half way to the desired open position and retighten bolts. Then close the operator onto the close stop roller, loosen the crank arm bolts, position the door in the closed position (1 1/4" past daylight) and tighten. This will lengthen the crank arm dimension, increasing the travel.

Open the door onto the open stop roller and check the door position. If the door is not in the proper open position, repeat the above steps until correct positions are reached and then ensure all the bolts are properly tightened.

Remember the stop rollers are factory set and should not be adjusted. Make sure that in both directions the operator stops against the stop roller and the operator links and bearings are not under stress.

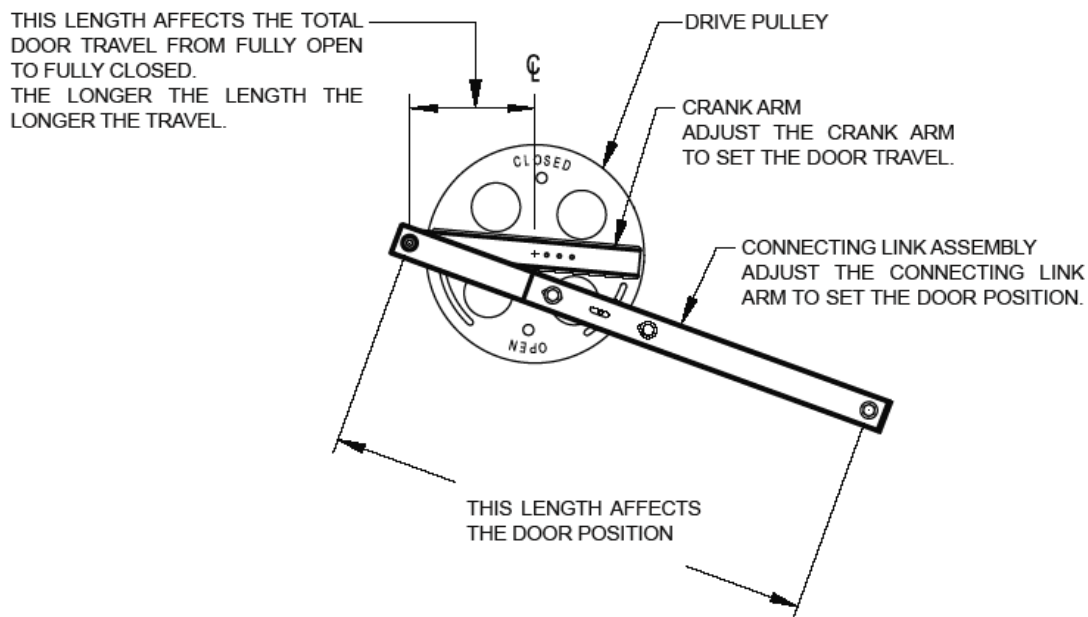

Figure 1: Drive pulley and connecting link assembly.



## 5. ADJUSTING SIDE SLIDE DOORS - SINGLE SPEED AND TWO SPEED

### 5.1. CRANK ARM AND CLUTCH LINK POSITIONS WITH DOOR CLOSED

The door closed is the most important position. Always end adjustments by checking this position. With the door closed and overlaps checked, the car doors should not be closed against a bumper or the strike jamb. Clearance of 1/16" is recommended. Mark the door position on the header for easier reference and repeating.

Mount the operator arms per appropriate template. To adjust, ensure the operator is closed against the stop and loosen the connecting link and crank arm bolts. Position the door to the closed position and re-tighten all bolts. If necessary, move the bolts to new holes.

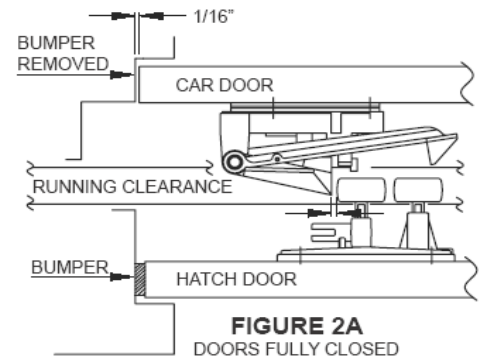

Referring to Figure 2, with the door fully closed, the crank arm should be a few degrees above the horizontal and the clutch link about 20 degrees above the horizontal. This setting will help prevent slamming, yet still allow manual opening of the doors when the car is stopped at a landing during a power failure.

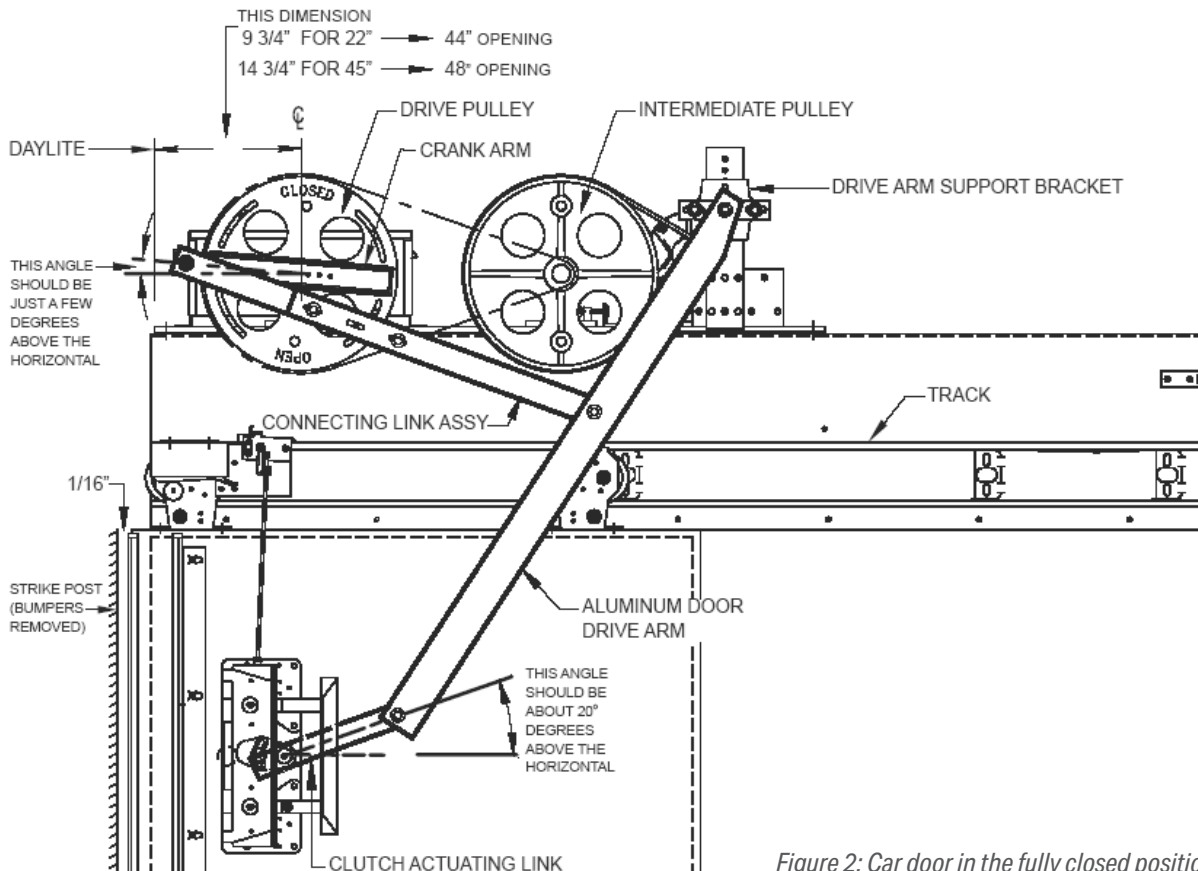

Figure 2: Car door in the fully closed position.

## 5.2. CRANK ARM AND CLUTCH LINK POSITIONS WITH DOOR OPEN

While opening and closing the door, please move the door manually. Check for binding to ensure maximum bearing life.

Referring to Figure 3, the best door opening operation occurs when the crank arm and the connecting link are roughly in a straight line (this holds the doors open against the force of the spring or reel closer). The clutch link is about horizontal and the car door is flush with the return jamb.

If the door does not open flush with the return jamb, adjust the connecting link to bring the door half way to the correct position. Then close the door and adjust the crank arm for door closed position (see previous section). Reopen door and check opening. Repeat as necessary.

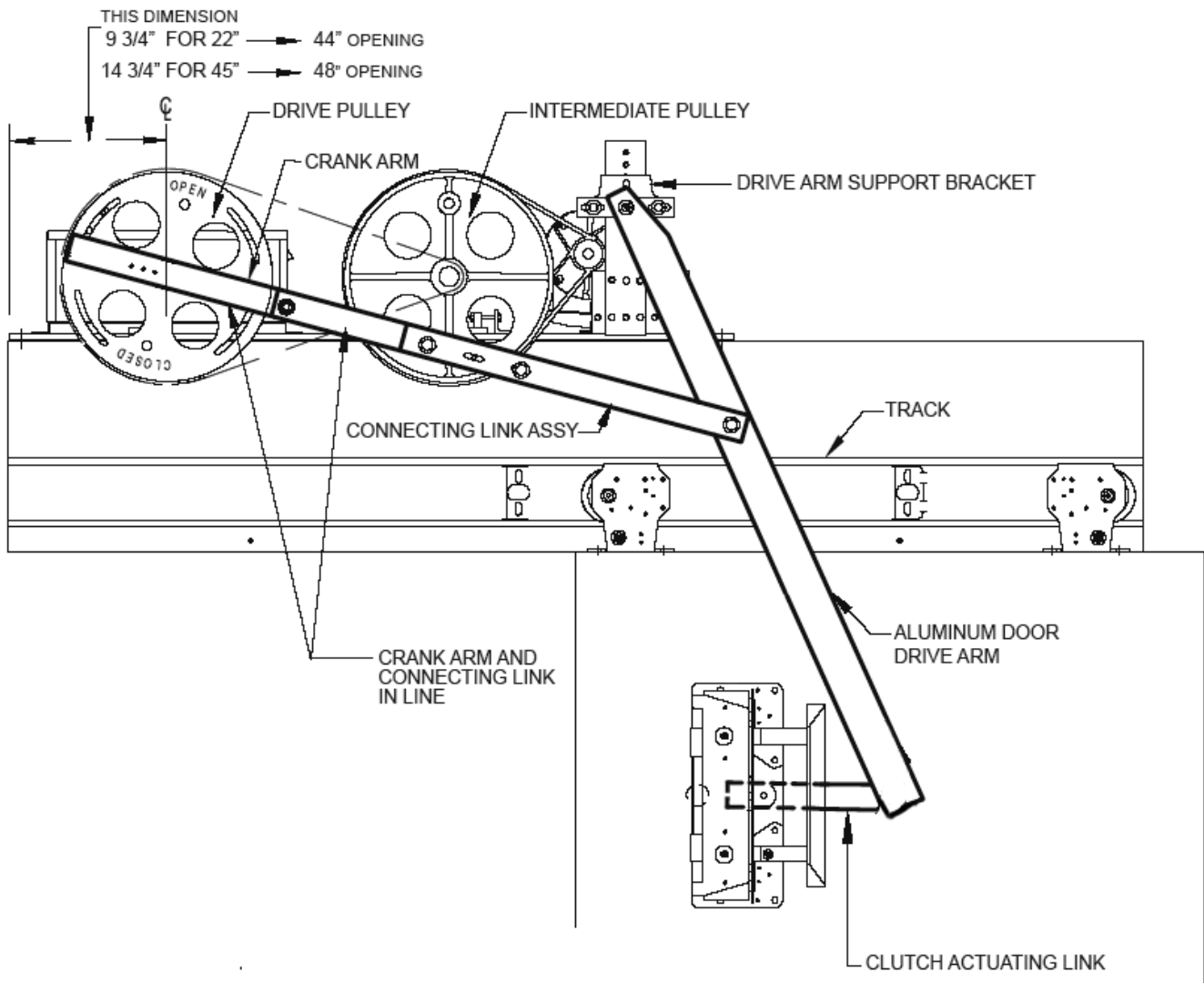

Figure 3: Car door in the fully open position.

## 6. ADJUSTING CENTER PARTING CAR DOORS

We recommend adjusting the driven car door so that it over travels the center of the opening by 1/2". This will allow the car door to match the hoistway door and jambs when fully open (if a double clutch system is used, center the doors). The car doors should not be closed hard against each other. Mark the door position on the header for easier reference and repeating.

**NOTE:** Center parting doors should be set up as two separate operations. First, set up the left (clutch side) door and then the right (driven side) door. The door closed is the most important position. Always end adjustments by checking this position.

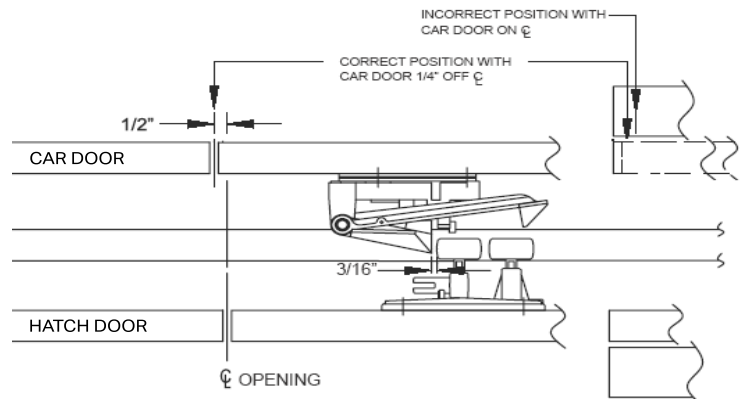

Figure 4: Clutch alignment.

### 6.1. CRANK ARM AND CLUTCH LINK POSITIONS WITH DOOR CLOSED

Do not have pressure on the meeting car doors. Otherwise, it will place unwanted stress on the arms and bearings.

Mount the operator arms per appropriate template. To adjust, ensure the operator is closed against the stop and loosen the connecting link and crank arm bolts. Position the door being adjusted in the closed position and re-tighten all bolts. If necessary, move the bolts to new holes.

Referring to Figure 5, with the doors fully closed, the connecting links should be about 1 1/2" from the horizontal centerline of the pulley. The clutch link should be at about 20 degrees above the horizontal as shown. This setting will help prevent slamming, yet still allow manual opening of the doors when the car is stopped at a landing during a power failure.

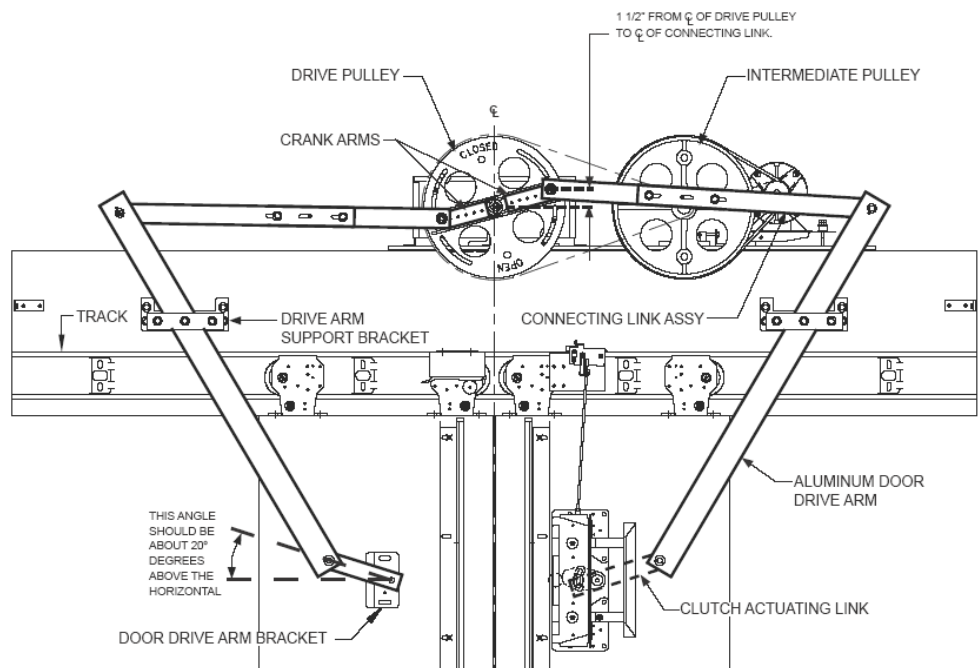

Figure 5: Center parting car doors in the fully closed position.

## 6.2. CRANK ARM AND CLUTCH LINK POSITIONS WITH DOORS OPEN

While opening and closing the door, please move the door manually. Check for binding to ensure maximum bearing life.

As with side slide doors, the best door opening operation occurs when the crank arm and the connecting link are roughly in a straight line (this holds the doors open against the force of the spring or reel closer). The clutch actuating link should be about horizontal when the car door is flush with the return jamb.

If the door does not open flush with the return jamb, adjust the connecting link to bring the door half way to the correct position. Then close the door and adjust the crank arm for door closed position (see previous section). Reopen door and check opening. Repeat as necessary.

Referring to Figure 6, with the doors fully open, the connecting links should be about 1 1/2" apart. The clutch link should be no more than 10 degrees above the horizontal.

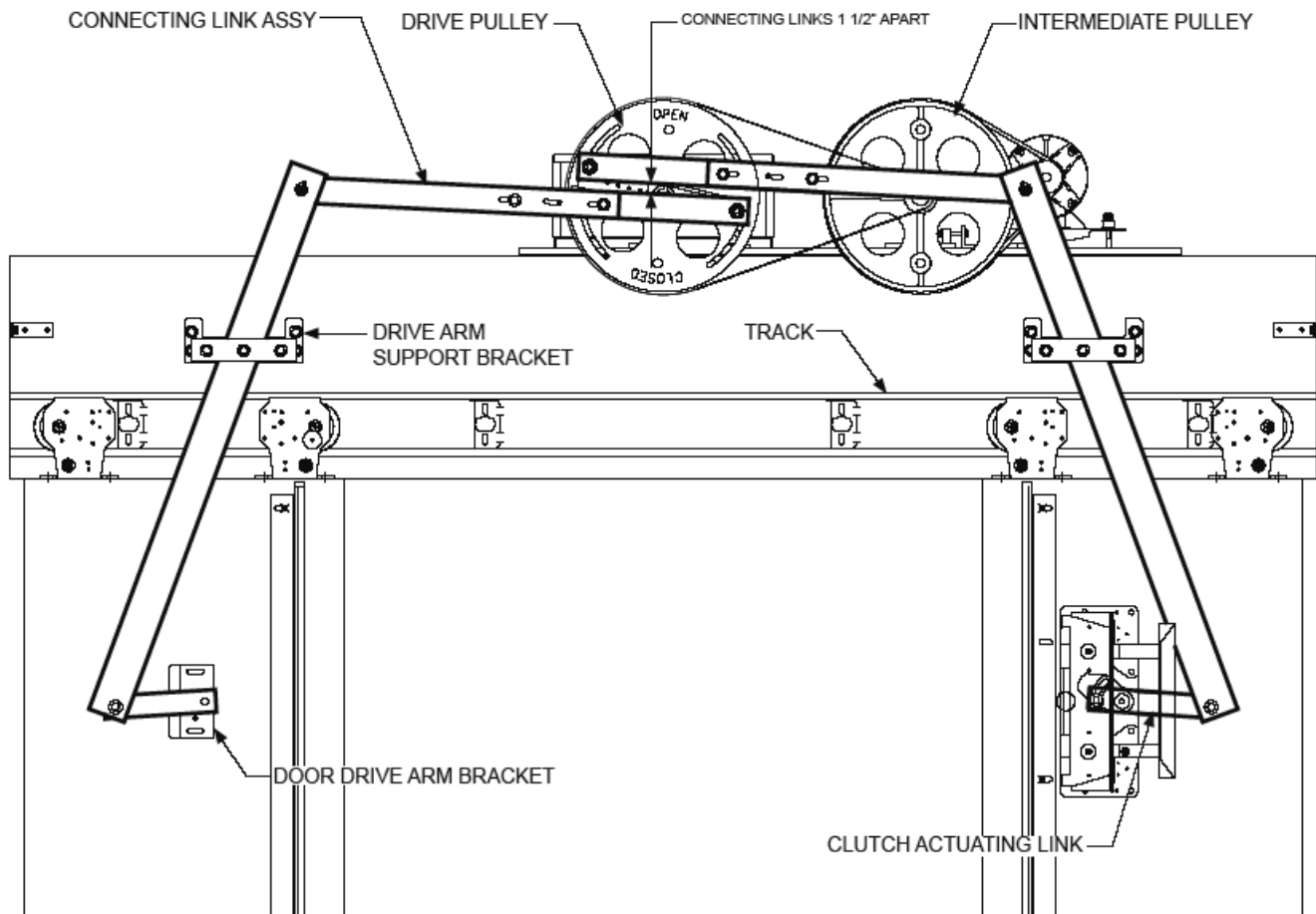
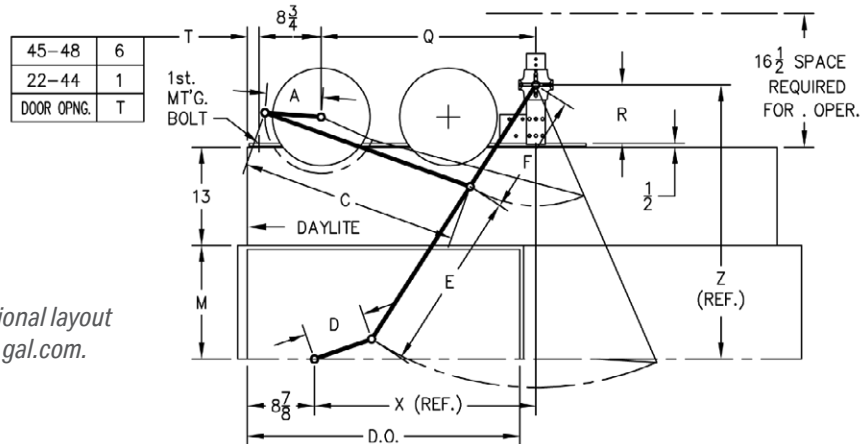

Figure 6: Center parting car door in the fully open position.

# 7. OPERATOR DATA TABLES FOR SIDE SLIDE AND CENTER PARTING DOORS



48	10 1/16	34 5/16	12	31	21	23	39 5/8	47 1/2	33 3/4	11
47	9 7/8	34 1/8	12	31	21	23	39 5/8	47 1/2	33 3/4	11
46	9 1/16	33 1/8	12	31	21	23	39 5/8	47 1/2	33 3/4	11
45	9 1/2	33 3/4	12	31	21	23	39 5/8	47 1/2	33 3/4	11
44	9 7/8	34 3/4	10	26	20	19	34 5/8	42	33 3/4	9 1/2
43	9 1/16	34 9/16	10	26	20	19	34 5/8	42	33 3/4	9 1/2
42	9 7/16	34 3/8	10	26	20	19	34 5/8	42	33 3/4	9 1/2
41	9 3/16	34 3/16	10	26	20	19	34 5/8	42	33 3/4	9 1/2
40	9	34	10	26	20	19	34 5/8	42	33 3/4	9 1/2
39	8	29 3/8	8	24	16	15	29 1/4	36 1/4	28 3/8	7 3/4
38	7 13/16	29 7/16	8	24	16	15	29 1/4	36 1/4	28 3/8	7 3/4
37	7 5/8	29	8	24	16	15	29 1/4	36 1/4	28 3/8	7 3/4
36	7 7/16	28 13/16	8	24	16	15	29 1/4	36 1/4	28 3/8	7 3/4
35	7 1/4	28 5/8	8	24	16	15	29 1/4	36 1/4	28 3/8	7 3/4
34	6 1/2	25 3/16	6	25	15	15	25 1/4	37	24 3/8	8 1/2
33	6 3/8	25	6	25	15	15	25 1/4	37	24 3/8	8 1/2
32	6 1/8	24 1/4	6	25	15	15	24 1/2	37 3/8	23 1/2	8 7/8
31	5 15/16	24 1/16	6	25	15	15	24 1/2	37 3/8	23 1/2	8 7/8
30	5 3/4	23 7/8	6	25	15	15	24 1/2	37 3/8	23 1/2	8 7/8
29	6 3/4	27 1/8	10	19	15	11	27 3/4	32	26 7/8	7 1/2
28	6 9/16	26 1/16	10	19	15	11	27 3/4	32	26 7/8	7 1/2
27	6 3/8	26 3/4	10	19	15	11	27 3/4	32	26 7/8	7 1/2
26	6 3/16	26 9/16	10	19	15	11	27 3/4	32	26 7/8	7 1/2
25	6	26 3/8	10	19	15	11	27 3/4	32	26 7/8	7 1/2
24	5 1/2	25 3/8	10	18	14	11	25 7/8	30 3/4	25	6 1/4
23	5 7/16	25 7/16	10	18	14	11	25 7/8	30 3/4	25	6 1/4
22	5 1/8	25	10	18	14	11	25 7/8	30 3/4	25	6 1/4
INCHES	A	C	D	E	F	M	X	Z	Q	R
DOOR OPENING	OPERATOR ARMS		DOOR ARMS			CLUTCH	PIVOT		OPERATOR	



SINGLE SPEED 22-48 D.O. OPERATOR DATA TABLE

NOV. 11, 1994  
DATA21

# MOVFR<sup>3</sup> Door Operator Installation & Adjustment Manual

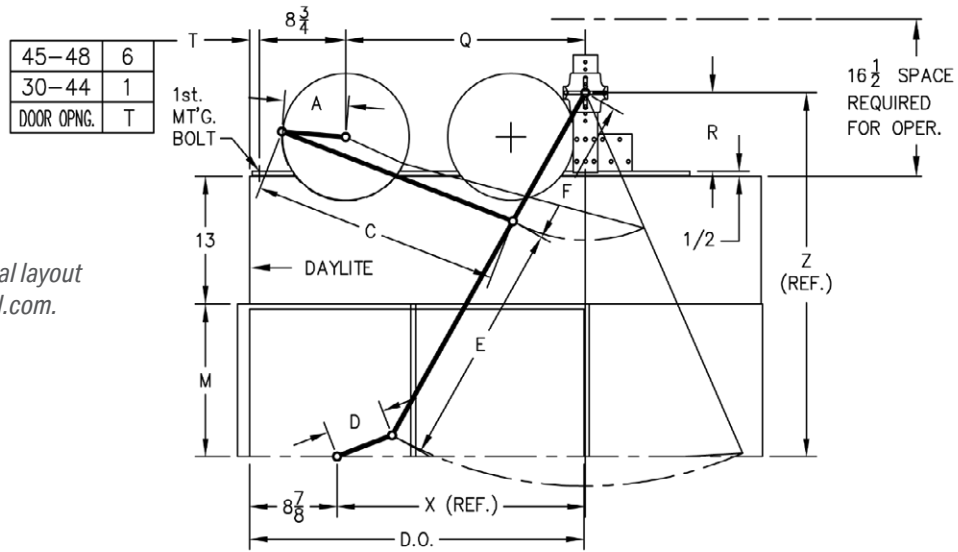



Note: Additional layout available at gal.com.

48	10 1/16	34 5/16	12	31	21	23	39 5/8	47 1/2	33 3/4	11	
47	9 7/8	34 1/8	12	31	21	23	39 5/8	47 1/2	33 3/4	11	
46	9 11/16	33 15/16	12	31	21	23	39 5/8	47 1/2	33 3/4	11	
45	9 1/2	33 3/4	12	31	21	23	39 5/8	47 1/2	33 3/4	11	
44	9 7/8	34 3/4	10	26	20	19	34 5/8	42	33 3/4	9 1/2	
43	9 11/16	34 9/16	10	26	20	19	34 5/8	42	33 3/4	9 1/2	
42	9 7/16	34 3/8	10	26	20	19	34 5/8	42	33 3/4	9 1/2	
41	9 3/16	34 3/16	10	26	20	19	34 5/8	42	33 3/4	9 1/2	
40	9	34	10	26	20	19	34 5/8	42	33 3/4	9 1/2	
39	8	29 3/8	8	24	16	15	29 1/4	36 1/4	28 3/8	7 3/4	
38	7 13/16	29 3/16	8	24	16	15	29 1/4	36 1/4	28 3/8	7 3/4	
37	7 5/8	29	8	24	16	15	29 1/4	36 1/4	28 3/8	7 3/4	
36	7 7/16	28 13/16	8	24	16	15	29 1/4	36 1/4	28 3/8	7 3/4	
35	7 1/4	28 5/8	8	24	16	15	29 1/4	36 1/4	28 3/8	7 3/4	
34	6 1/2	25 3/16	6	25	15	15	25 1/4	37	23 7/8	8 1/2	
33	6 3/8	25	6	25	15	15	25 1/4	37	23 7/8	8 1/2	
32	6 1/8	24 1/4	6	25	15	15	24 1/2	37 3/8	23 1/2	8 7/8	
31	5 13/16	24 1/16	6	25	15	15	24 1/2	37 3/8	23 1/2	8 7/8	
30	5 3/4	23 7/8	6	25	15	15	24 1/2	37 3/8	23 1/2	8 7/8	
INCHES	A	C	D	E	F	M	X	Z	Q	R	
DOOR OPENING	OPERATOR ARMS		DOOR ARMS			CLUTCH	PIVOT		OPERATOR		
		TWO SPEED 30-48 D.O. OPERATOR DATA TABLE								AUG. 23 1994	
										DATA22	

# MOVFR<sup>3</sup> Door Operator Installation & Adjustment Manual

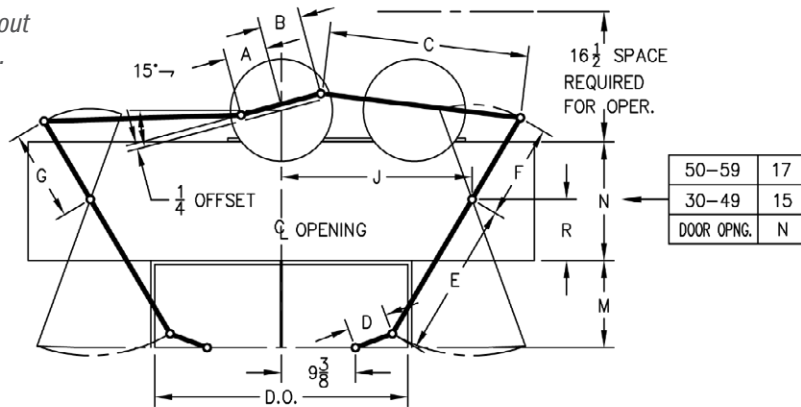
Note: Additional layout available at gal.com.



59	7 3/4	8 3/16	35	8	29 1/2	15	14 1/2	19	7 3/4	34
58	7 5/8	8 1/16	35 1/8	8	29 1/2	15	14 1/2	19	7 3/4	34
57	7 1/2	7 15/16	35 1/4	8	29 1/2	15	14 1/2	19	7 3/4	34
56	7 3/8	7 13/16	35 3/8	8	29 1/2	15	14 1/2	19	7 3/4	34
55	7 1/4	7 11/16	35 1/2	8	29 1/2	15	14 1/2	19	7 3/4	34
54	6 7/16	7 1/2	34	8	29 1/2	15	13	19	8 1/2	33
53	6 5/16	7 3/8	34 3/16	8	29 1/2	15	13	19	8 1/2	33
52	6 3/16	7 1/4	34 5/16	8	29 1/2	15	13	19	8 1/2	33
51	6 1/16	7 1/8	34 7/16	8	29 1/2	15	13	19	8 1/2	33
50	5 15/16	7	34 9/16	8	29 1/2	15	13	19	8 1/2	33
49	5 13/16	6 1/4	29 5/8	6	25 1/2	12	11 1/2	15	8 1/4	29
48	5 11/16	6 1/8	29 3/4	6	25 1/2	12	11 1/2	15	8 1/4	29
47	5 9/16	6	29 7/8	6	25 1/2	12	11 1/2	15	8 1/4	29
46	5 7/16	5 7/8	30	6	25 1/2	12	11 1/2	15	8 1/4	29
45	5 5/16	5 3/4	30 1/8	6	25 1/2	12	11 1/2	15	8 1/4	29
44	5 3/16	5 5/8	29 1/8	6	25 1/2	12	11 1/2	15	8 5/8	28 1/4
43	5 1/16	5 1/2	29 1/4	6	25 1/2	12	11 1/2	15	8 5/8	28 1/4
42	5 1/16	5 3/8	29 3/8	6	25 1/2	12	11 1/2	15	8 5/8	28 1/4
41	4 15/16	5 1/4	29 1/2	6	25 1/2	12	11 1/2	15	8 5/8	28 1/4
40	4 13/16	5 1/8	29 5/8	6	25 1/2	12	11 1/2	15	8 5/8	28 1/4
39	5 7/8	6 1/8	27 1/2	6	21	12	11 1/2	11	8 1/2	26 5/8
38	5 5/8	5 15/16	27 5/8	6	21	12	11 1/2	11	8 1/2	26 5/8
37	5 1/2	5 13/16	27 3/4	6	21	12	11 1/2	11	8 1/2	26 5/8
36	5 5/16	5 5/8	27 7/8	6	21	12	11 1/2	11	8 1/2	26 5/8
35	5 1/8	5 1/2	28	6	21	12	11 1/2	11	8 1/2	26 5/8
34	5	5 5/16	28 1/8	6	21	12	11 1/2	11	8 1/2	26 5/8
33	5 3/16	5 9/16	25 1/16	5	19 3/4	12	11 1/2	11	7 3/4	24 1/8
32	5 1/16	5 3/8	25 3/16	5	19 3/4	12	11 1/2	11	7 3/4	24 1/8
31	4 15/16	5 1/4	25 5/8	5	19 3/4	12	11 1/2	11	7 3/4	24 1/8
30	4 13/16	5 1/8	25 1/2	5	19 3/4	12	11 1/2	11	7 3/4	24 1/8
INCHES	A	B	C	D	E	F	G	M	R	J
DOOR OPENING	OPERATOR ARMS		DOOR ARMS				CLUTCH	PIVOT		
 CENTER OPENING 30-59 D.O. OPERATOR DATA TABLE								NOV. 11, 1994		
								DATA23		

# **MOVFR<sup>3</sup>**

## **ELECTRICAL ADJUSTMENTS**



## 8. ELECTRICAL ADJUSTMENTS

### 8.1. OVERVIEW

The block diagram and simplified control algorithm of the MOVFR<sup>3</sup> Operator are illustrated below:

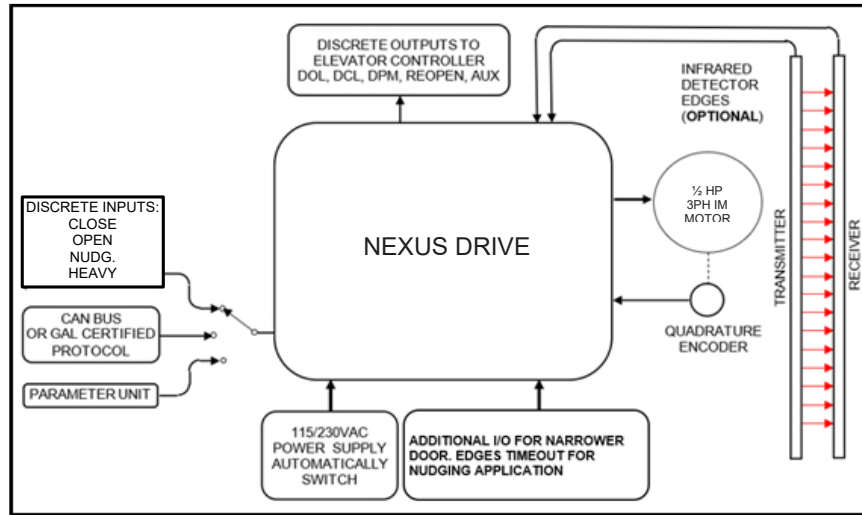

Figure 7: Block diagram of the MOVFR<sup>3</sup> Operator.

### 8.2. THE NEXUS DRIVE

The MOVFR<sup>3</sup> is powered by the NEXUS Drive, which is capable of driving a Harmonic IM Motor Operator, a Linear IM Motor Operator, and a Linear PM Motor Operator.

Below is a diagram of the NEXUS Drive:

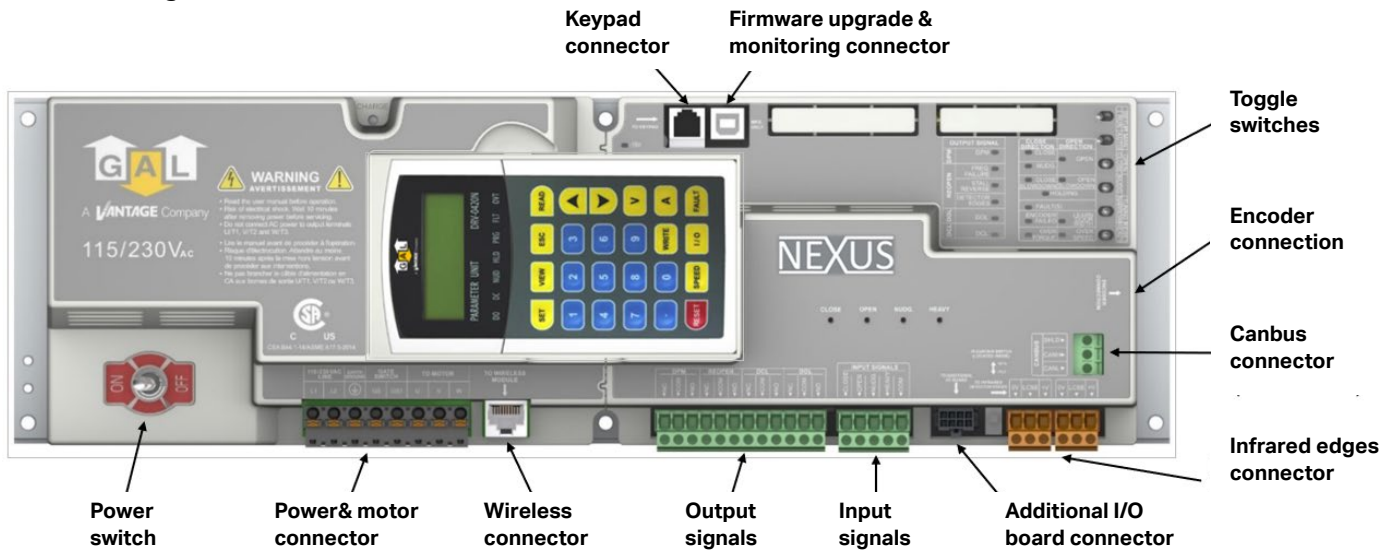

Figure 8: The anatomy of the NEXUS Drive.

## 8.2.1. Toggle switches

Six toggle switches are provided for users to adjust the NEXUS Drive and MOVFR<sup>3</sup> Operator. These switches can perform the following functions:

- Learning the door width
- Tuning
- Troubleshooting
- Operating the doors in manual mode
- Verifying the operation of the door

See the Table below for a description of the function of each switch:

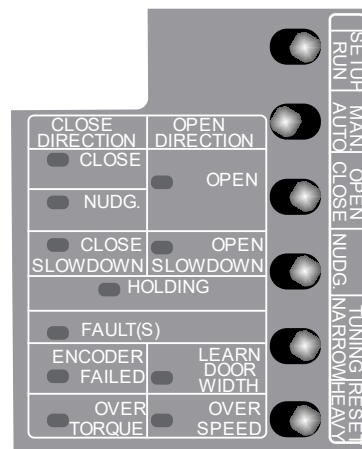

Figure 9: NEXUS Toggle Switches

SWITCH LABEL	POSITION	FUNCTION
RUN/ SETUP	RUN	Allows the operator to run in normal operation.
	SETUP	Allows users to adjust certain Parameters that cannot be changed during operation. Puts the drive into STOP mode, and no power will be delivered to the motor.
AUTO/ MAN.	AUTO	Allows the operator to run in normal operation.
	MAN.	Allows opening and closing the door by means of the OPEN/CLOSE, NUDG., NARROW, and HEAVY toggle switches.
OPEN/ CLOSE	OPEN	Opens the door when the AUTO/MAN. switch is in the MAN. position.
	CLOSE	Closes the door when the AUTO/MAN. switch is in the MAN. position.
NUDG.	NUDG.	Allows closing the door at a reduced speed (Nudging speed). To test the Nudging speed in Manual mode, flip the RUN/SETUP to the RUN position & AUTO/MAN. to the MAN. position. The CLOSE/OPEN and NUDG. switches must be pressed to the CLOSE and NUDG. positions.
NARROW/ TUNING	NARROW	If toggle is in NARROW position, allows operator to work in conjunction with OPEN/CLOSE and NUDG. switches if RUN/SETUP switch is set to RUN position and AUTO/MAN. is set to MAN. position.
	TUNING	Used to learn the door width during setup. See Easy Tuning section on page __.
HEAVY/ RESET	HEAVY	If toggle is in HEAVY position, allows operator to work in conjunction with OPEN/CLOSE and NUDG. switches if RUN/SETUP switch is set to RUN position and AUTO/MAN. is set to MAN. position.
	RESET	The RESET position allows a manual reset of faults if faults have occurred in the drive. Otherwise, pressing the RESET side has no effect.

## 8.2.2. LED Indicators

A red LED is provided on each of the input modules (Open, Close, Nudge., or Heavy). There are more LEDs, on the mainboard, to indicate the completion of the door tuning, the directions, the final limit positions, nudging, holding, dynamic slowdown distances, input signals, output signals, and voltage levels as shown below.

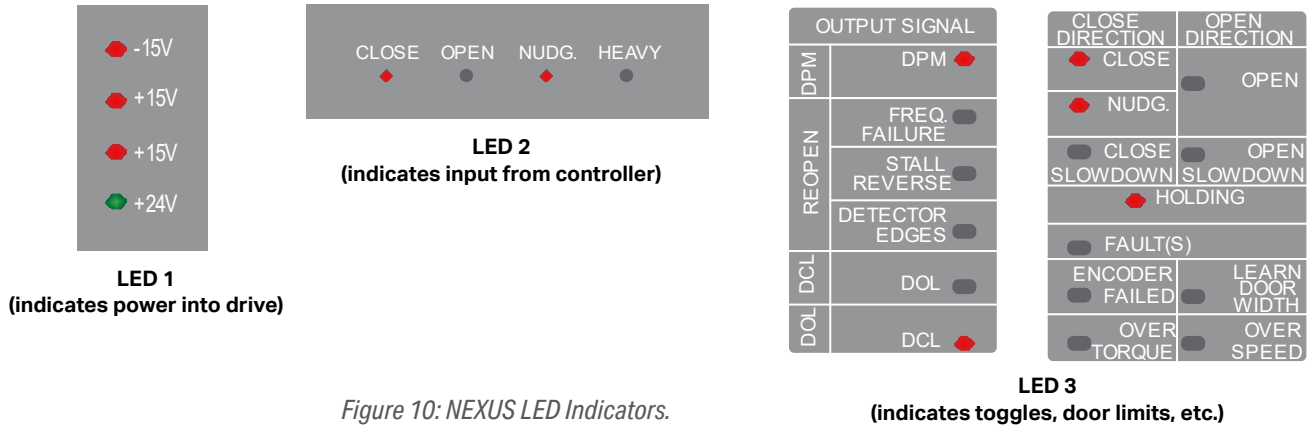

Figure 10: NEXUS LED Indicators.

## 8.2.3. Inputs

Four inputs are provided to interface with OPEN, CLOSE, NUDGE, and HEAVY commands from the elevator controller.

These *universal inputs* accept control signals either in the form of dry contacts or signal voltages from 24-230V AC or DC. LEDs of the input modules draw currents from the elevator controller, not from the MOVFR<sup>3</sup>. Therefore, these LEDs must be lit to indicate that the elevator controller sent commands. In AUTO mode, the MOVFR<sup>3</sup> will only monitor input signals from the elevator controller, not from toggle switches.

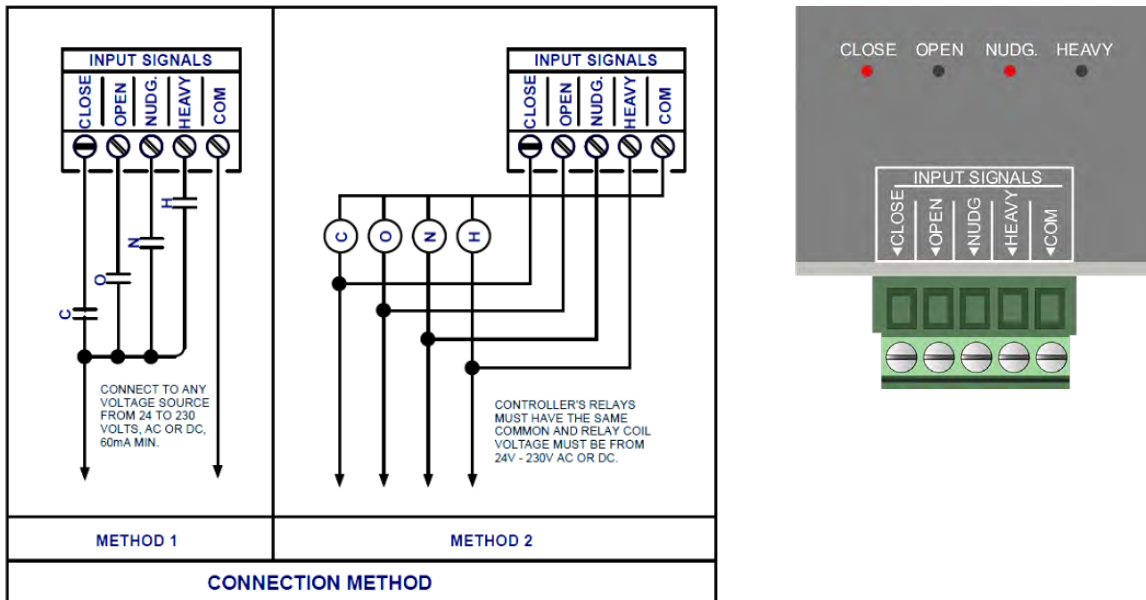

Figure 11: Input connection Methods 1 & 2.

## 8.2.4. Outputs

There are four relay outputs DPM, RE-OPEN, DCL, and DCL signals in the form of contacts. The relay contacts are rated at 10Amp, 250VAC maximum, and 100mA, 12VAC minimum.

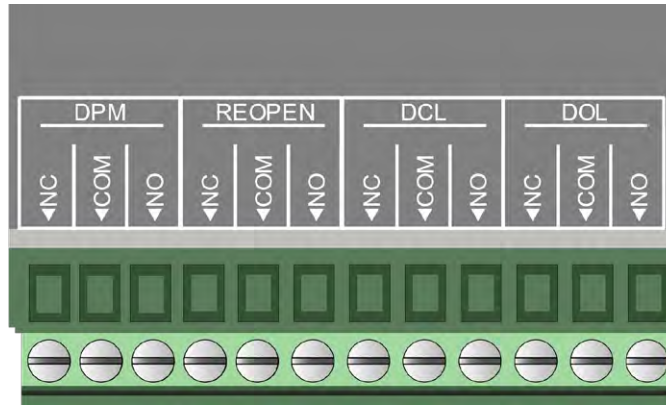

Figure 12: NEXUS output terminals.

LED LABEL	MEANING	FUNCTION
<b>DPM</b>	Door Protection Monitor	DPM is designed to work with the Fault Monitor (FM). FM is a patented door lock and gate switch protection device. Its purpose is to meet the ASME A17.1 RULE 210.15 and CAN/CSA-B44-M90 RULE 3.12.1.5. The setting position of DPM is ½ inch before the gate switch makes.  DPM position can be modified by adjusting Parameter 66.
<b>REOPEN</b>	Door Re-Open	This output is used to flag the elevator controller that the door needs to be reopened. The reopen output DOES NOT reopen the door directly. The signal to reopen the door must come from the elevator controller. Re-open relay is triggered by one of the following detections:  <b>STALL REVERSE:</b> controlled by Parameter 148  <b>DETECTOR EDGES:</b> controlled by Parameter 202
<b>DCL</b>	Door Close Limit	After learning the door width, NEXUS will assign the DCL output signal at the fully closed position of the door.
<b>DOL</b>	Door Open Limit	After learning the door width, NEXUS will assign the DOL output signal at the fully open position of the door.

## 8.2.5. Encoder connection

The encoder is connected to the NEXUS drive with a DB9 to RJ12 adapter.

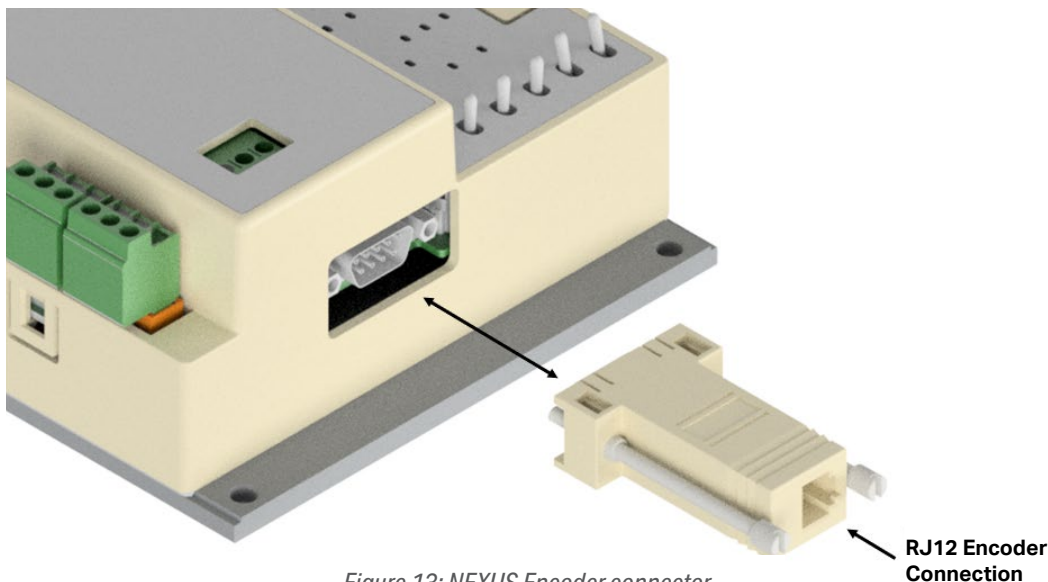

Figure 13: NEXUS Encoder connector.

## 8.2.6. CANbus

If Controller Area Network (CAN) Protocol (only used for GALaxy Controllers) is employed to communicate with the MOVFR, a CANbus Module MOVFE-0009N must be used. The CANbus card comes pre-installed on all NEXUS Drives to CAN communication with the controller.

### TO ENABLE CAN BUS:

1. Set the RUN/SETUP switch to SETUP
2. Set Par. 11 = 5.
3. Set the RUN/SETUP switch to RUN.
4. Set the AUTO/MAN to AUTO

Other communication protocols are also available upon request. However, an agreement between GAL and the requesting party must be made prior to the implementation of the communication protocols. Contact GAL for more details on CAN or other protocols.



Figure 14: CANBUS wire terminals (left) and module, MOVFE-0009N (right).

## 8.2.7. Infrared Detector Edges

To simplify connections between infrared detector edges, and the elevator controller, GAL offers GAL Certified Infrared Detector Edges. These infrared detector edges can be connected directly to the NEXUS Drive. The procedure below will assist users to plug-and-play GAL Certified Infrared Detector Edges with the NEXUS Drive.

If the edge detectors are not connected to the NEXUS Drive, set Par. 202 = 0 to disable.

**NOTE:** Connectors labeled [0V | LCSE | +V are interchangeable.

### 8.2.7.1. Output Type: NPN or PNP

The edge detector output type should be obtained prior to installation. If the type is not known, read the label on the cover tube or the detector edges' manual to determine if the detector edges are NPN or PNP. Set the selector switch accordingly.

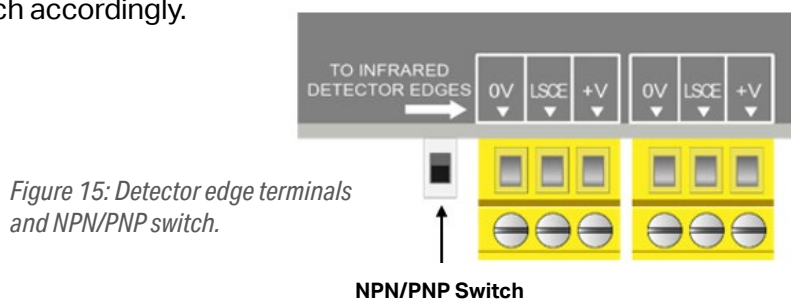

Figure 15: Detector edge terminals and NPN/PNP switch.

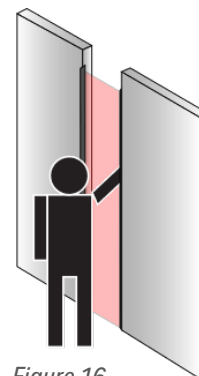

Figure 16

If the output type is unavailable, use the trial-and-error method described below:

1. Assume that the edges' output is NPN for the 1st trial.
2. Set Par. 202 = 1 for NPN type and ensure that the NPN/PNP switch is set to NPN. See Figure 15 above.
3. Cycle the doors and break the light curtain to trigger a Re-Open signal. The DETECTOR EDGES LED should be on. See Figures 16 & 17.
4. If the doors reopen, success! If not, continue to step 5. NOTE: Make sure the REOPEN output contact is connected to the elevator controller.
5. Set Par. 202 = 2 for PNP type and flip the NPN/PNP switch to PNP.
6. Cycle the doors and break the light curtain to trigger a Re-Open signal. The doors should REOPEN.

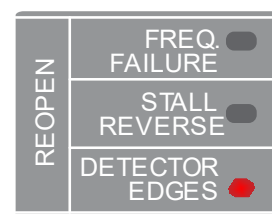

Figure 17

### 8.2.7.2. Testing Detector Edges

Perform the following procedure to test the functionality of the detector edges:

1. Set the RUN/SETUP switch to RUN and the MAN/AUTO switch to AUTO. Allow the doors to close.
2. As the doors close, obstruct the infrared light curtain to trigger the detector edge. The DETECTOR EDGES LED should be on. See Figures 16 & 17.
3. The REOPEN relay should be activated to send the REOPEN signal to the elevator controller.
4. The elevator controller will send the DOOR OPEN command signal to the NEXUS DRIVE to REOPEN the door. THE LED of the OPEN Input module should be on.

## 8.2.7.3. Troubleshooting Detector Edges

If the Detector Edges are not working, try these steps:

- Check the manual for correct connections between the edges and the NEXUS Drive.
- Check for 24VDC between the 0V and +V on either CN2 or CN3
- Repeat the test procedure outlined in Section 8.2.7.2.

If the Detector Edges still not work, try the following:

- Jump 0V to LCSE on either CN4 or CN5 connector for NPN Type.
- Jump +V to LCSE on either CN4 or CN5 connector for PNP Type.
- The DETECTOR EDGES LED should be OFF.
- The REOPEN Relay should be activated. If not, the problem is in the NEXUS Drive.

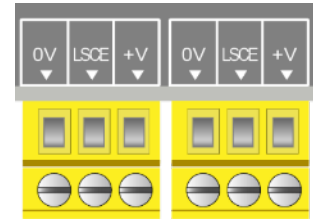

Figure 18: Detector edge terminals.

If the above step works as described, the problem is in the Detector Edges.

If the infrared Detector Edges have intermittent problems:

- Check the continuity of the TX and RX cables of the infrared detector edges.
- If the cables are good but the problem persists, check the ground connection to the edges.
- Users may need to lower the Carrier Frequency in Par. 1 gradually until the problem is resolved.

**NOTE:** Lowering the carrier frequency may create more audible noise in the motor.

## 8.2.7.4. The Advantages of Using GAL Certified Detector Edges

- Users do not need to use an extra power supply for the detector edges.
- The REOPEN relay used for the infrared detector edges has two (2) more safety features to reopen the door. They are over-speed and over-torque detections.

## 8.2.7.5. Identifying GAL Certified Detector Edges and Connections

GAL CERTIFIED INFRARED DETECTOR EDGE CONNECTION									
GAL P/N	Manufacturer	TX			RX			CONNECTION BETWEEN TX & RX	REMARKS
		V+	LCSE	0V	V+	LCSE	0V		
DPTT-0004N	TRITRONICS	RED	WHITE	ORANGE				NONE	2D
DPFS-1004N	FORMULA SYSTEMS	BLUE 1	BROWN 2	GREEN YELLOW	BLUE 1	BROWN 2	GREEN YELLOW	NONE	2D
DPFS-0015N	FORMULA SYSTEMS	BLACK 1	NONE	GREEN YELLOW	BLACK 1	BLACK 3	GREEN YELLOW	BLACK #2 OF TX & RX	BLACK #3 OF TX IS NOT USED. 3D EDGE
DPSG-0008N	GAL SCANGUARD	BROWN	NONE	BLUE	BROWN	BLACK	BLUE		2D

## 8.3. INITIAL SETUP

GAL has performed the initial wiring prior to shipping the MOVFR<sup>3</sup> to users. The following procedure is described below to guide users through the initial setup process.

**1. Connect main power** to the NEXUS Drive. The drive can accept 115 or 230 VAC.

**2. Motor/Encoder Connection:** Verify that the motor and encoder connections are still secured after shipment and installation. Motor power connections are shown on right in Figure 19. The encoder connection is shown on page 21 in Figure 13.

**3. Interlock/Edge Detector:** Check that the door interlock or gate switch is wired into terminals GS and GS1 (Shown in Figure 19 above. (To the right of the ground connection.)) If detector edges are used, verify the connections shown in Figure 19.

**4. Power on:**



**5. Easy Tuning<sup>®</sup> Method:**

1. Manually close the door until it is **fully closed**.
2. Set the RUN/SETUP toggle to SETUP
3. Set the MAN/AUTO toggle to MAN
4. Set Par. 63 = 1.
5. Flip the TUNING/NARROW toggle towards TUNING
6. Follow the prompts on the parameter unit. Use the keypad or arrow keys to adjust the value. Press WRITE to enter and move to the next prompt.
  - Select Motor and Operator Type
  - Enter door speed
  - Enter door opening size (in inches)
  - Enter door weight (in lbs)

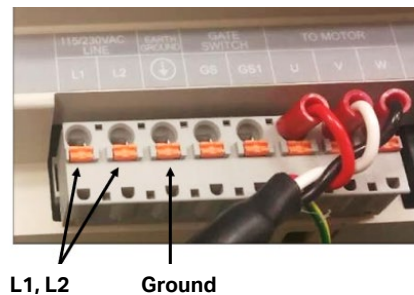

Figure 19: NEXUS power, ground, gate switch, and motor terminals.

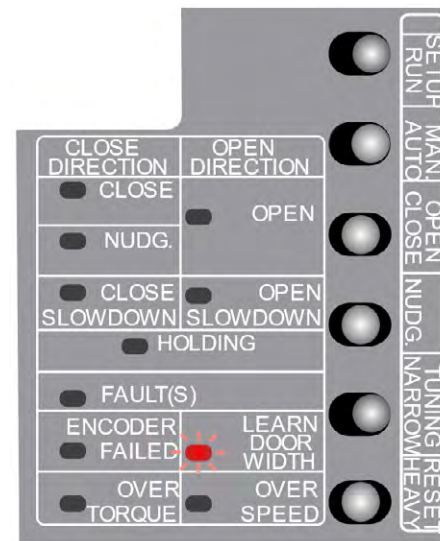

Figure 20: NEXUS toggles and LEDs.

The LEARN DOOR WIDTH LED should be flashing during the tuning process. It will turn off after tuning is complete.

**During learning, the following sequence of events will occur:**

1. The doors will open slightly and then close. Parameter unit will display "Door Dir Learned"
2. Next, the doors will open fully and the parameter unit will display "Open Limit Learned". Then the doors will close and display "Close Limit Learned".
3. The door will close and then open/close two more times, after which the parameter unit will display "Door Learn Complete".



## 8.4. THE NEXUS PARAMETER UNIT

The parameter unit is a tool to assist users in the following tasks:

- Easy Tuning
- Changing speed values, acceleration, deceleration, torque, maximum closing speed, carrier frequency, and stall reverse limit.
- Downloading (copying/reading) and uploading (writing) programs to and from the drives.
- Monitoring currents, voltages, speeds, inputs, outputs, faults, and encoder directions.
- Resetting the drive in the event of a drive fault.

### 8.4.1. Parameter Unit Navigation

#### 8.4.1.1. How to change a parameter:

Press . Enter a Parameter Number.



Press . Enter a new Value. Press .

Wait for the Completed Signal from the Display

#### 8.4.1.2. How to read (COPY All Parameters) from the drive:

**Note 1:** The Parameter Unit is capable of storing four Sets of Default Parameters and one set of Working Parameters. To Copy a Default Set of Parameters into the Working Set Parameters, see **item 8** of **Section 8.4.1.6**.

**Note 2:** To Transfer data from one drive to another, users must first READ (COPY) from the First Drive.

Press . Press .

Press . Wait for the Completed Signal from the Display.

#### 8.4.1.3. How to write (DOWNLOAD All Parameters) to the drive:

Set SETUP/RUN switch to SETUP.

Press . Press .

Press . Wait for the Completed Signal from the Display.



Figure 21: NEXUS Parameter Unit

## 8.4.1.4 Default settings for the MOVFR<sup>3</sup> NEXUS Drive:

CLOSING	PARAMETER #		RANGE	DEFAULT VALUE			
	REG.	HVY		C/P		S/O	
				REG.	HVY.	REG.	HVY.
HOLDING TORQUE	137	152	0-100	82.4	82.4	82.4	82.4
HOLDING SPEED	138	153	0-180	5.1	5.1	5.1	5.1
HIGH SPEED HSC	141	156	0-180	24.3	24.3	24.3	24.3
FINAL SPEED FSC	142	157	0-180	5.3	2.8	11.5	2.8
NUDGING SPD	144	159	0-180	20	20	20	20
ACCELERATION TIME	145	160	.1-100	1.5	1.5	1.5	1.5
DECELERATION TIME	146	161	.1-100	3	3	3	3
STALL REV. FORCE	148	163	0-150	72	52	72	52

OPENING	PARAMETER #		RANGE	DEFAULT VALUE			
	REG.	HVY		C/P		S/O	
				REG.	HVY.	REG.	HVY.
QUICK STOP ON REV.	78	92	0-200	180	180	180	180
SLOW START SSO	82	96	0-180	11.3	11.3	11.3	11.3
HIGH SPEED HSO	84	98	0-180	47	47	47	47
FINAL SPEED FSO	85	99	0-180	17.8	2.8	17.8	2.8
ACCELERATION TIME	87	101	.1-100	1.7	1.7	1.7	1.7
DECELERATION TIME	88	102	.1-100	1.7	1.7	1.7	1.7

C/P = Center Parting Door

S/O = Side Opening Door

REG. = Regular Doors

HVY. = Heavy Doors

## 8.4.1.5. Convenience keys:

Press **SPEED** to check the Speed in Hz

Example: 

Output	Frequency
HSC	19Hz

Press **I/O** to check Input & Output Signals.

### Inputs:

<b>Z:</b> (Reserved)	<b>C:</b> Door Close	<b>O:</b> Door Open
<b>R:</b> Reset	<b>V:</b> Heavy Door	<b>L:</b> Control Bit L
<b>M:</b> Control Bit M	<b>H:</b> Control Bit H	

### Outputs:

<b>S:</b> Over Speed	<b>T:</b> Over Torque	<b>F:</b> Fault
----------------------	-----------------------	-----------------

Example: 

Z	C	O	R	V	L	M	H	S	T	F
0	1	0	0	0	1	0	0	0	0	0

Press **FAULT** to check the recent Faults.

Press **▼** or **▲** to view all the Faults

Example: 

Present	Fault
Under	Voltage

Press **V** to check the Output Voltage.

Example: 

Output	Voltage
	132.00v

Press **A** to check the Output Current.

Example: 

Output	Current
	.078A

Press **RESET** to Reset the Drive.

## 8.4.1.6. The **VIEW** keys:

Press the **VIEW** key will allow users to view, change, and reset to G.A.L. Default parameters.

Press **▲** or **▼** to navigate through all the items in the VIEW section.

Press **VIEW** to view an item. At any time, Press **ESC** to get back to the Previous Display.

1. **V/I/H** Displays the Output Voltage, Output Current, Command Speed, and Actual Speed.

2. **I/O** Displays the Input and Output Signals

**ZCORVLMH STF** 1= Activate 0= Deactivate

(See the **Convenience keys** in Section 8.4.1.5)

3. **Faults.** (See the **Convenience keys** in Section 8.4.1.5)

Press  or  to View all the Faults.



4. **Counters.** There are 2 Counters.

Counter 1 will count up to 9,999 times.

Counter 2 will count up to 60,000 times.

When Counter 1 reaches 9999, Counter 2 will increase 1

The total count will be 600,000,000 times.

Press  or  to View Counter 1 or Counter 2.

5. **User List.**

The User List includes all the **Default settings for the MOVFR drive** in Section 8.4.1.4.

Press , Press  or  to view all the Parameters in the User List.

**NOTE:** Users can also change the Value of Parameters in this stage by doing the following:

Press , Enter the new value, then Press .

Press  to get back to the Previous Display.

6. **Max. cl. Speed**

Press  to view the Maximum Closing Speed.

Press  to get back to the Previous Display.

7. **Max. cl. Force**

Press  to view the Maximum Closing Force.

Press  to get back to the Previous Display.

8. **GAL Defaults**

Press , Press  or  to pick one of the four sets of Parameters

Standard C/P (Center Parting)

Standard S/O (Side Opening)

Waterproof C/P (Center Parting)

Waterproof S/O (Side Opening)

Set RUN/CAM SETUP switch to CAM SETUP

Press  to copy the chosen set of Parameters to the Working Set of Parameters

## 8.4.1.7. LED indicators:

There are 7 LEDs on the Parameter Unit. DO, DC, NUD, HLD, PRG, FLT, OVT. DO=Door Open, DC=Door Close, NUD=Nudging, HLD=Holding, PRG=Programming Mode, FLT=Fault, OVT=Over Torque. These LEDs indicate the present status of the MOVFR.

## 8.5. PARAMETER ADJUSTMENTS

---

**CAUTION!** All equipment must be installed and adjusted to meet Federal, State/Provincial, and Local Codes.

**NOTE 1:** The closing Kinetic Energy is affected by the speed and the mass of the door. The closing Kinetic Energy must not exceed Code Limits. For more details about the Kinetic Energy of the G.A.L. door operators, go to the section of **Kinetic Energy & G.A.L. Door Operators** of the link:

<https://www.gal.com/wp-content/uploads/2019/05/overview.pdf>

**NOTE 2:** The Closing Torque is affected by the Torque adjustment. **The Closing Torque must not exceed Code Limits.**

**NOTE 3:** Whenever changing any value in the Closing Direction Parameters, the door should be rechecked to meet the Code requirement.

### A. Closing sequence:

**MAXIMUM CLOSE SPEED** (Par. 141): This Parameter is the Limit of the Closing speed. The Default value of this Parameter is 30Hz. If the Closing speed is higher than 30Hz, the Drive will turn on the Frequency Failure (FF) output and activate the Reopen Relay. Users should bear in mind that the Reopen Relay Contact, once activated, will send the re-open signal to the Main Controller ONLY and will wait for the OPEN signal from the Main Controller to Reopen the door. MOVFR will NOT reopen the door by itself.

**HOLDING TORQUE** (Par. 137): The Holding Torque is activated when the door reaches DOL or DCL.

**HOLDING SPEED** (Par. 138): The Holding Speed is activated when the door reaches DOL or DCL.

**NOTE:** The reason to apply the Holding Power when the door is fully closed or fully open is to prevent the door from drifting or rolling back.

**CAUTION!** The Holding power should be less than 15W to prevent the motor from unnecessary heating, which would reduce its life.

**HIGH SPEED CLOSE – HSC** (Par. 141): This is the highest speed for the overall Closing sequence. A higher value produces the faster speed.

**FINAL SPEED CLOSE – FSC** (Par. 142): This is the Final Closing Speed. It should be set reasonably low so that when the DCL (Door Close Limit) and the Close Stop Roller are reached without slamming or bouncing.

**FINAL SPEED CLOSE START** (Par. 143): This is the point in the door travel where the door enters Final Speed Close. The parameter is set as a percentage of the total door travel and defaults to 6% for SS and 14% for CP. Meaning that for side slides, the final 6% of door travel is performed in Final Speed Close. Increase the parameter to extend the duration that the door travels in Final Speed Close.

**NUDGING SPEED** (Par. 144): Nudging Speed is the reduced speed that is equal or less than 60% of the max. HSC. Nudging Speed only happens when DC (Door Close) and NUDG. (Nudging) input signals take place simultaneously.

**CLOSE ACCELERATION TIME** (Par. 145): A higher value produces a slower acceleration rate for smoother operation. A lower value produces a faster acceleration rate for faster opening times.

**CLOSE DECELERATION TIME** (Par. 146): Close Deceleration should be set so that the FSC is reached prior to the DCL and the Close Stop Roller position without bouncing.

**STALL REVERSE FORCE** (Par. 148): The Default value of this Parameter is 1.5Amp. Whenever the current is above this value, the Drive will send a signal to turn on the STALL REVERSE LED and activate the REOPEN Relay. The range for this Parameter is 0-2Amp. If nuisance activation takes place, the value of this Parameter should be increased slightly.

**OVERLOAD** (Par. 136): This is the Maximum Limit of the Motor Current. If the Motor Current exceeds this Limit, the Drive will be shutdown, generate the OVER CURRENT FAULT, and turn on the FAULT LED. Recycling the Power to MOVFR or pressing the RESET key of the Parameter Unit to Reset the Fault. However, a thorough inspection should be done before Resetting the Fault.

## B. Opening Sequence:

**QUICK STOP ON REVERSE** (Par. 78): Parameter 78 determines how quick the closing door is stopped when a reopen signal is activated. The range of Parameter 78 is from 0 to 6Amp. The lower value setting will produce a longer time to stop before the door can reopen. When the reopen signal is applied, the door should not move more than 2 inches before it reopens.

**SLOW START OPEN – SSO** (Par. 82): When the door starts to open, the value of Par. 82 is the speed at which the clutch engages the interlock rollers to unlock the hoistway door. A slower speed produces a smoother and quieter unlock.

**HIGH SPEED OPEN – HSO** (Par. 84): This is the highest speed for the overall opening sequence. The higher value produces a faster speed.

**MEDIUM SPEED OPEN – MSO** (Par. 84): This speed is used for a fast reopening in the final 1/3 to 1/4 of the opening. When properly adjusted, this speed has little or no effect during the full reopening cycle because the doors will decelerate through MSO zone. Virtually the doors will decelerate from HSO to FSO.

**FINAL SPEED OPEN – FSO** (Par. 85): This is the Final Opening Speed. It should be set reasonably low so that the DOL (Door Open Limit) and the Open Stop Roller are reached without slamming or bouncing.

**OPEN ACCELERATION TIME** (Par. 87): A higher value produces a slower acceleration rate for smoother operation. A lower value produces a faster acceleration rate for faster opening times.

**OPEN DECELERATION TIME** (Par. 88): Open Deceleration should be set so that the FSC is reached prior to the DCL and the Close Stop Roller position without bouncing.

## C. Carrier frequency:

**CARRIER FREQUENCY** (Par. 1): The nominal frequency of the carrier wave is set by Parameter 1. The Default value is 10KHz. The MOVFR Drive is compliant with the CE regulation. However, if adjacent electronics, with poor EMI immunity, are affected by EMI of the MOVFR, users can lower the value of this Parameter to reduce the EMI level. The trade-off is the lower carrier frequency, the more audible noise will be produced by the motor.

## 8.6. THE NEXUS DRIVE

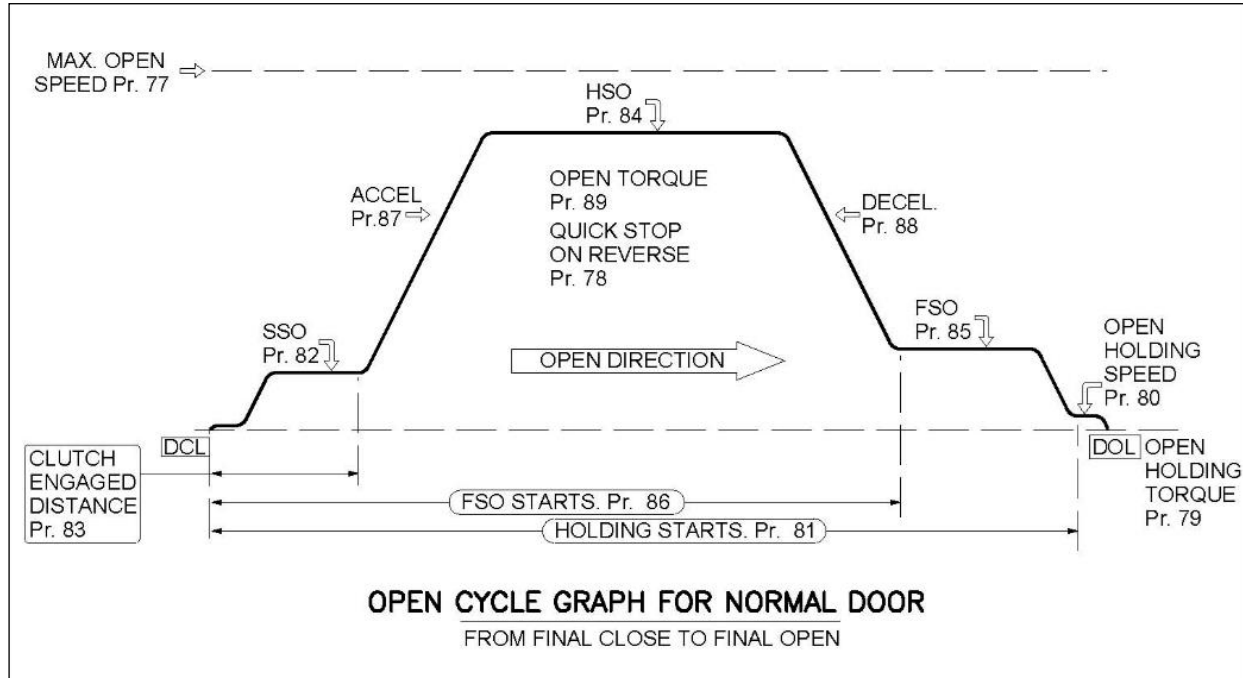

Figure 22: Open Cycle Speed Profile

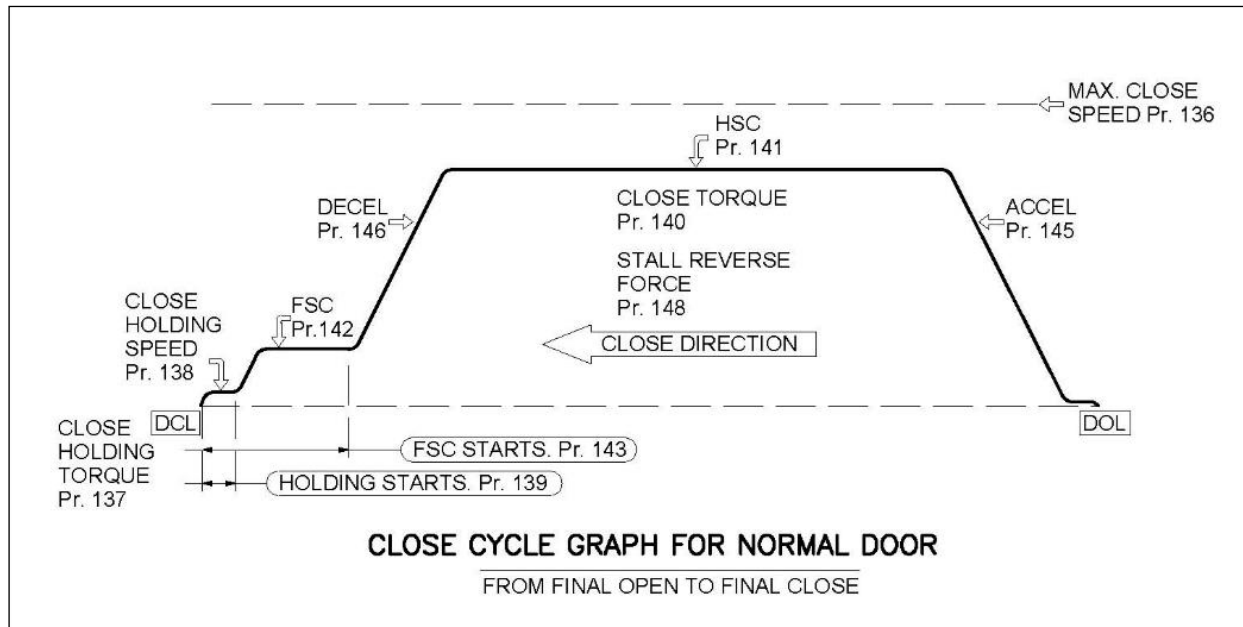

Figure 23: Close Cycle Speed Profile

## 8.7. HEAVY DOOR APPLICATION

The same elevator may have two different hoist-way doors with one set being heavier than the others. Another scenario is the door may be under the high pressure of the ambient environment, i.e., wind pressure. As a result, the settings of Torque and Speed of one door may not be applicable for the other. More importantly, it may be a code violation issue due to the constraint of Kinetic energy and the Torque allowance.

The HEAVY input of the MOVFR<sup>3</sup> will resolve this issue. When the HEAVY input is activated, the MOVFR<sup>3</sup> will operate with a different set of parameters to accommodate the heavier weight.

To gain access to the parameters of the HEAVY door, users need to provide a command signal to the HEAVY input as indicated below. The HEAVY input is a universal input module that accepts the control signal either in the form of contacts or voltages, 24 - 230V AC or DC. The LED of the input module draws current from the elevator controller, not from the MOVFR<sup>3</sup>. Therefore, the LED needs to light up to indicate that the elevator controller has sent the HEAVY command.

To learn a "Heavy Door" floor follow the procedure below:

1. Bring the car to the Heavy Door floor to be learned and align with hoistway roller release
2. Manually Close the Door; Turn the Power SW ON if it is not already
3. Set RUN/SETUP toggle to SETUP
4. Set MAN/AUTO toggle to MAN
5. Momentarily pressy the HEAVY/RESET toggle towards HEAVY
6. Hold TUNING/NARROW toggle towards TUNING for 3 seconds
7. Follow prompts on parameter unit

When the drive is given a Heavy Door input it will now use information learned at this floor. Heavy floors use their own parameter set which are Par. 91-102, and Par. 152-164.

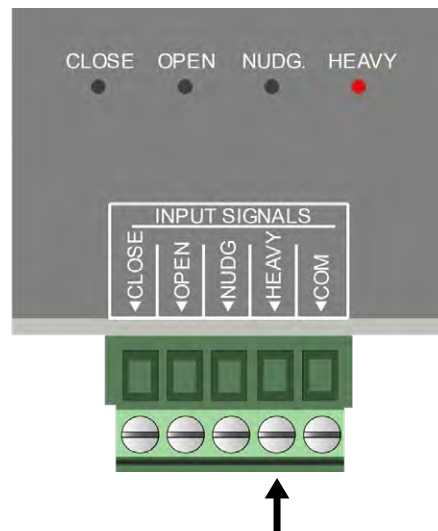

Figure 24: Heavy door input location (indicated).



## 8.8. DOOR STALL FORCE MEASUREMENT

The most practical way to measure the stall force of the door is to use a spring gauge as shown in Figure 25 below.

Stall force is the static force to prevent the door from further moving.

Stop the door anywhere from one-third to two-thirds of the door travel. Press the spring gauge against the door, remove the stop. Hold the spring gauge until the door stands still and take the reading.

The stall force must be less than 30 Lbs to comply with ASME, A17.1, Rule 112.4/5, and CSA/B44, Rule 2.13.4/5.



Figure 25: Spring gauge

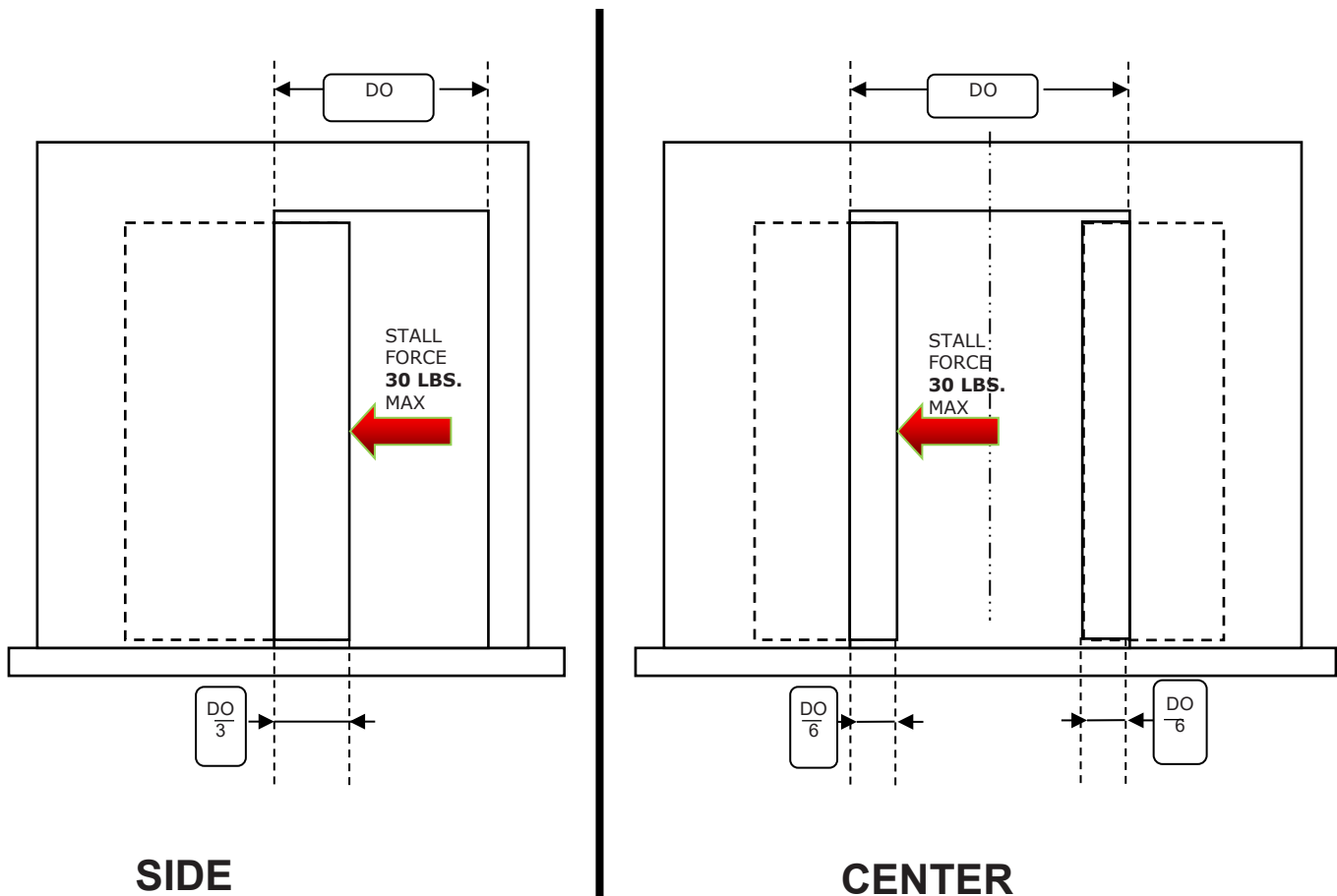

Figure 26: Force measurement locations for side and center parting doors

## 8.9. HOW TO REPLACE THE DRIVE

1. Before disconnecting the drive from power, copy the parameters from the old drive by following the directions in Section 8.4.1.2.
2. Disconnect the door operator power from the machine room.
3. Flip the POWER SWITCH to the OFF position. Wait a few minutes for the drive's internal capacitors to completely discharge.
4. Disconnect the POWER & MOTOR CONNECTOR from the drive. The terminal block can be easily pried up from the drive. The wires should not be disconnected individually.
5. Disconnect the OUTPUT SIGNAL, INPUT SIGNAL, and INFRARED EDGES CONNECTOR terminal blocks from the drive. Again, the wires should not have to be disconnected individually.
6. If used, disconnect the CANBUS CONNECTOR wires from the drive.
7. Disconnect the ENCODER CONNECTOR from the drive, including the RJ12 adapter.
8. Remove the GROUND SCREWS from the drive.
9. Remove the MOUNTING SCREWS from the drive and set the old drive aside.
10. Install the new drive in place of the old drive and secure it using the MOUNTING SCREWS.
11. Secure the ground screws and ground wires to the new drive.
12. Connect the ENCODER to the new drive.
13. If used, connect the CANBUS wires to the new drive.
14. Connect the OUTPUT SIGNAL, INPUT SIGNAL, INFRARED EDGES CONNECTOR, and POWER & MOTOR CONNECTOR terminal blocks to the new drive.
15. Flip AUTO/MAN toggle to MAN and flip the POWER SWITCH to the ON position.
16. Using the parameter unit, write the parameters to the drive as described in Section 8.4.1.3.
17. Use the OPEN/CLOSE toggle to manually cycle the doors. If doors operate as expected, flip AUTO/MAN toggle to AUTO and perform a car call test to verify the elevator is working properly.

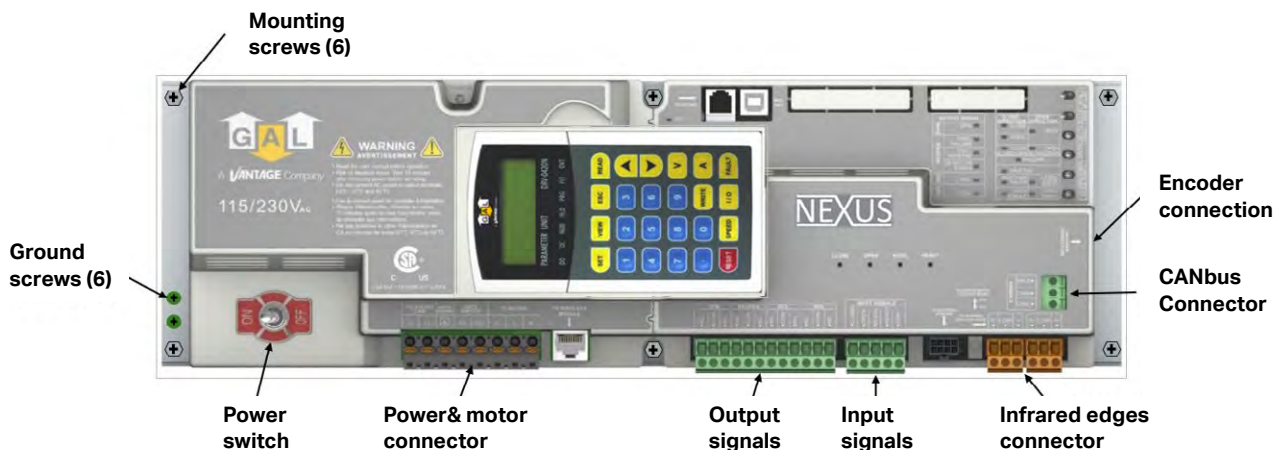

Figure 27: The NEXUS Drive with removeable connections and wire terminal blocks indicated.

## 9. PARAMETER LIST

User Parameters:

PAR	FUNCTIONS	MAX	MIN	DEFAULT		SETTING	LCD Text	
				C/P	I/O		Description (16bit)	Unit (4 bit)
0	Stop Mode	3	0	3	3	0: Free Run 1: 1st Open & Close Decel Time 2: 2nd Open & Close Decel Time 3: The Fast Decel Time	Stop Mode	
1	Carry Frequency	15	2	10	10	2~15 kHz	Carry Freq.	kHz
2	Parameter Reset	9999	0	0	0	06: Clear all fault record 08: Keypad lock 10: Reset all Parameters	Parameter Reset	
10	Auto Voltage Regulation	2	0	0	0	0: AVR function enable 1: AVR function disable 2: AVR function disable for decel.	AVR Function	
11	Operate Source	6	0	1	1	1: External terminals. 3: RS-485 communication. 5. CAN Bus 6. Bluetooth	Start Source	
15	User Group Read Selection	65535	0	0	0	1206 : for GAL (ALL PARAMETER)	User Group selection	

## Motor and Encoder Parameters:

PAR	FUNCTIONS	MAX	MIN	DEFAULT		SETTING	LCD Text	
				C/P	I/O		Description (16bit)	Unit (4 bit)
26	Maximum Output Voltage	240.0	0.0	220.0	220.0	0.0V to 240.0V, should be higher than Pr.28	Motor Rated Volt	V
27	Max Output Freq.	120.00	0.00	66.66	66.66	0.00 to 120.00 Hz, should be higher than Pr.29	Max. Speed	Hz
28	MIN Output Voltage	100.0	0.0	0.0	0.0	0~100.0% of Pr.26	Min. Voltage	%
29	Min Output Freq.	120.00	0.00	0.00	0.00	0.00 to 120.00 Hz, should be lower than Pr.27	Min. Output Spd	Hz
30	PM Motor Auto-Tuning	2	0	0	0	00: Disable 01: Auto-tuning for PM motor parameters 02: Auto-tuning for PG offset angle without load	PM Auto tuning	
31	PM Motor Rated Current	4.20	0.70	2.23	2.23	FLA*5% ~ FLA*120% (FLA=3.0A)	PM Rated Current	A
32	PM Motor Rated Power	655.35	0.00	0.34	0.34	Read automatically by setting Pr.31	PM Rated Power	Kw
33	PM Motor Rated Speed	65535	0	500	500	Read automatically by setting Pr.31	PM Rated Speed	rpm
34	PM Motor Pole Number	96	2	16	16	02 ~ 96	Poles of PM	pol
35	PM Motor Rs	655.35	0.00	4.21	4.21	0.00~655.35 Ω	PM Rs	ohm
36	PM Offset Angle	360.0	0.0	90.0	90.0	0.0~360.0 deg	PM Offset Angle	deg
37	IM Motor Auto-Tuning	2	0	0	0	0: No function 1: Rolling test 2: Static test	IM Auto tuning	
38	IM Motor Rated Current	4.20	0.70	2.30	2.30	FLA*5% ~ FLA*120% (FLA=3.0A)	IM Rated Current	A
39	IM Motor No-Load Current	pr.38	0.00	0.88	0.88	40% of pr.38	IM NL Current	A
40	IM Motor Rated Power	655.35	0.00	0.37	0.37	IM Rated Power	Kw	
41	IM Motor Rated Speed	65535	0	1140	1140	IM Rated Speed	rpm	
42	IM Motor Pole Number	48	2	6	6	02 ~ 48	Poles of IM	pol
43	IM Motor Rs	65.535	0.000	8.765	8.765	0.00~65.535 Ω	IM Rs	ohm
44	Encoder Pulses	25000	0	500	500	0 ~ 25000	Pulse per rev.	pls
45	Encoder fbk Input Setting	2	0	1	1	00: Disable 01: Forward / Counterclockwise rotation 02: Reverse / Clockwise rotation	Encoder Input	
46	PG fbk Speed Deviation Level	79.99	0.00	69.00	69.00	0.00 ~ 79.99 Hz	Fbk Deviation	Hz
47	Spd fbk Error Detect Time	10.0	0.0	0.3	0.3	0.0 ~ 10.0 sec	Fbk Error Time	sec
48	Sensorless Enable for PM	2	0	0	0	0: Fault and stop 1: Fault and auto-reset for keeping operation 2: Fault and auto-reset for keeping operation. Auto recover if PG is detected	Sensorless Enable	
49	Door Width (Inch)	65535	0	48	48	0~65535 inch	Door Width (inch)	"
50	Door Weight	1200	200	225	225	200 ~ 1500 lbs	Door Weight	lbs
51	Door Speed	3	1	1	1	1: 1 Speed 2: 2 Speed 3: 3 Speed	Door Speed	
52	Door Type	6	1	1	2	1: Harmonic C/P + IM 2: Harmonic S/O + IM 3: Linear C/P + PM 4: Linear S/O + PM 5: Linear C/P + IM 6: Linear S/O + IM	Door Type	

## Door Parameters:

PAR	FUNCTIONS	MAX	MIN	DEFAULT		SETTING	LCD Text	
				C/P	I/O		Description (16bit)	Unit (4 bit)
58	Basic Tuning Speed Rate	100.0	50.0	77.0	77.0	50.0 ~ 100.0%	Btun Speed Rate	%
59	Stall Current Level of Learning	200.0	0.0	75.0	75.0	0.0~200.0%	Learning Current Lev	%
60	Close Average Kinetic Energy (Smart Tuning)	10.00	3.00	6.00	6.00	3.00 ~ 10.00 J (For Smart tuning)	Clos ave-kinetic	J
61	Scan Freq.	8.63	0.10	6.00	6.00	0.10 ~ 8.63Hz, should be lower than Pr.144 & Pr.159	Scan Spd	Hz
62	Learning Freq.	120.00	0.10	15.00	15.00	0.1 ~ 120.00Hz	Learning Spd	Hz
63	Auto-Learning	1	0	0	0	0: disable 1: enable	Learning Mode	
64	Regular Door Width	65535	0	8800	8800	0~65535pulse	Regular Width	pls
66	Advance DPM	100.0	0.0	15.0	15.0	0 ~ 100.0 %	Advance DPM	%
69	Code Distance Reg/Heavy	65535	0	8488	8488	1" FOR S/O, 2" FOR C/P FROM DCL	Code width reg.	
73	Stall Current Level of Scan	200.0	0.0	75.0	75.0	0.0 ~ 200.0%	Scan Current Lev. H	%

## Communication Parameters:

PAR	FUNCTIONS	MAX	MIN	DEFAULT		SETTING	LCD Text	
				C/P	I/O		Description (16bit)	Unit (4 bit)
240	RS485 Node Number (ADDR)	254	1	1	1	1 ~ 254	Comm Node Addr	
241	RS485 Baudrate (BPS)	3	0	1	1	0: Baud rate 4800bps 1: Baud rate 9600bps 2: Baud rate 19200bps 3: Baud rate 38400bps	Comm Data Rate	
242	RS485 Modbus Protocol (PROTOCOL)	5	0	3	3	0: 7,N,2 (Modbus, ASCII) 1: 7,E,1 (Modbus, ASCII) 2: 7,O,1 (Modbus, ASCII) 3: 8,N,1 (Modbus, RTU) 4: 8,E,1 (Modbus, RTU) 5: 8,O,1 (Modbus, RTU)	Comm Format	
243	RS485 Connection Loss	3	0	3	3	0: Warn and keep operating 1: Warn and ramp to stop 2: Warn and coast to stop 3: No warning and keep operating	Comm Loss Action	
244	RS485 Connection Loss Time	60.0	0.0	2.0	2.0	0.0 ~ 60.0 sec (0.0: Disable)	Comm Loss TM	sec
246	CAN Node Number (CAN ADDR)	255	0	7	7	0 ~ 255	CAN Node Addr	
247	CAN Baudrate (CAN BPS)	6553.5	0	0	0	0 ~ 6553.5kbps	CAN Data Rate	kbp

## Opening Parameters:

PAR	FUNCTIONS	MAX	MIN	DEFAULT		SETTING	LCD Text	
				C/P	I/O		Description (16bit)	Unit (4 bit)
76	Clutch Distance	576	320	320	320	320~576pulse	CLUTCH Distance	pls
77	ACC. Quick Stop Rev.	250.0	0.0	180.0	180.0	0.0 ~ 250.0% of Motor Rated Current	ACC. Quick Stp Rev.	%
78	Quick Stop Rev.	200.0	0.0	180.0	180.0	0.0 ~ 200.0% of Motor Rated Current	Quick Stp Rev.	%
79	Holding Torque	100.0	0.0	95.8	95.8	0.0~100.0% of 1.2 A	Open HLD Torque	%
80	Holding Speed	180.0	0.0	8.5	8.5	0.0 ~ 180.0% of Par.27, should be lower than Par.144	Open HLD Spd	%
81(95)	Holding Start	100.0	0.0	97.0	97.0	0 ~ 100.0 % of Door Width	Holding Start	%
82(96)	Slow Speed Open	180.0	0.0	11.3	11.3	0.0 ~ 180.0% of Par.27, should be lower than Par.144	Slow Spd SSO	%
83(97)	High Speed Open Start	100.0	0.0	5.0	5.0	0.0~100.0%	HSO Start	%
84	High Speed Open	180.0	0.0	47.0	47.0	0.0 ~ 180.0% of Par.27, should be lower than Par.126, higher than Par.144	High Spd HSO	%
85	Final Speed Open	180.0	0.0	17.8	17.8	0.0 ~ 180.0% of Par.27, should be lower than Par.144	Final Spd FSO	%
86(100)	Final Speed Open Start	100.0	0.0	95.0	95.0	0 ~ 100.0 % of Door Width	FSO Start	%
87	Open Acc. Time	100.0	0.1	1.7	1.7	0.1 ~ 100.0 sec	Open Acc. TM	sec
88	Open Dec. Time	100.0	0.1	1.7	1.7	0.1 ~ 100.0 sec	Open Dec. TM	sec
91	Hvy ACC. Quick Stop Rev.	250.0	0.0	180.0	180.0	0.0 ~ 250.0% of Motor Rated Current	Hvy HSO Start	%
92	Hvy Quick Stop Rev.	200.0	0.0	180.0	180.0	0.0 ~ 200.0% of Motor Rated Current	Hvy Quick Rev.	%
93	Hvy Holding Torque	100.0	0.0	95.8	95.8	0.0~100.0% of 1.2 A	Hvy Open HLD Tor	%
94	Hvy Holding Speed	180.0	0.0	8.5	8.5	0.0 ~ 180.0% of Par.27, should be lower than Par.159	Hvy Open HLD Spd	%
95(81)	Hvy Holding Start	100.0	0.0	97.0	97.0	0 ~ 100.0 % of Door Width	Hvy HLD Start	%
96(82)	Hvy Slow Speed Open	180.0	0.0	11.3	11.3	0.0 ~ 180.0% of Par.27, should be lower than Par.159	Hvy Spd SSO	%
97(83)	Hvy High Speed Open Start	100.0	0.0	5.0	5.0	0.0 ~ 100.0%	Hvy HSO Start	%
98	Hvy High Speed Open	180.0	0.0	47.0	47.0	0.0 ~ 180.0% of Par.27, should be lower than Par.126, higher than Par.159	Hvy Spd HSO	%
99	Hvy Final Speed Open	180.0	0.0	2.8	2.8	0.0 ~ 180.0% of Par.27, should be lower than Par.159	Hvy Spd FSO	%
100(86)	Hvy Final Speed Open Start	100.0	0.0	95.0	95.0	0 ~ 100.0 % of Door Width	Hvy FSO Start	%
101	Hvy Open Acc. Time	100.0	0.1	1.7	1.7	0.1 ~ 100.0 sec	Hvy Open Acc. TM	sec
102	Hvy Open Dec. Time	100.0	0.1	1.7	1.7	0.1 ~ 100.0 sec	Hvy Open Dec. TM	sec
126	Max. Open Speed	66.66	0.00	50.00	50.00	0.00 ~ 66.66Hz, should be lower than Par.27, higher than Par.84 & Par.98	Max. Open Spd	Hz
127	Open Timeout	180.0	0.0	0.0	0.0	0.0 ~ 180.0 sec (0.0: disable)	Open Timeout	sec
128	Open Lock Torq. 1	150.00	0.00	80.00	80.00	0.0 ~ 150.0% of Motor Rated Current	Open Lock Torq1	%
129	Open Lock Torq. 2	150.00	0.00	80.00	80.00	0.0 ~ 150.0% of Motor Rated Current	Open Lock Torq2	%
130	Open Holding Time	999.9	0.0	0.0	0.0	0.0 ~ 999.9 sec	sec	
131	Open Acc S-Curve	10.0	0.0	0.4	0.4	0 ~ 10.0 sec	Open Acc Scurve	sec
132	Open Acc S-Curve2	10.0	0.0	0.4	0.4	0 ~ 10.0 sec	Open Acc Scurve2	sec

## Closing Parameters:

PAR	FUNCTIONS	MAX	MIN	DEFAULT		SETTING	LCD Text	
				C/P	I/O		Description (16bit)	Unit (4 bit)
136	Close Obstruct Limit Force	54.0	0.0	38.0	38.0	0.0 ~ 54.0% of Motor Rated Current	Clo Obstruct LIM	%
137	Holding Torque	100.0	0.0	82.4	82.4	0.0~100.0% of 1.2 A	Close HLD Torq.	%
138(153)	Holding Speed	180.0	0.0	5.1	5.1	0.0 ~ 180.0% of Par.27, should be lower than Par.144	Close HLD Spd	Hz
139(154)	Holding Start	100.0	0.0	6.0	6.0	0 ~ 100.0 % of Door Width	Holding Start	%
141	High Speed Close	180.0	0.0	24.3	24.3	0.0 ~ 180.0% of Par.27, should be lower than Par.185, higher than Par.144	High Spd HSC	%
142	Final Speed Close	180.0	0.0	5.3	11.5	0.0 ~ 180.0% of Par.27, should be lower than Par.144	Final Spd FSC	%
143(158)	Final Speed Close Start	100.0	0.0	6.0	6.0	0 ~ 100.0 % of Door Width	FSC Start	%
144	Nudging Speed	180.0	0.0	20.00	20.00	0.0 ~ 180.0% of Par.27, should be lower than Par.141, higher than Par.61, Par.80, Par.82, Par.85, Par.138, Par.142 & Par.150	Nudging Spd	%
145	Close Acc. Time	100.0	0.1	1.5	1.5	0.1 ~ 3600.0 sec	Close Acc. TM	sec
146	Close Dec. Time	100.0	0.1	3.0	3.0	0.1 ~ 3600.0 sec	Close Dec. TM	sec
147	Acc. Stall Rev. Force	200	100	120	120	100 ~ 200% of Motor Rated Current	Stall Rev Acc	%
148	Stall Rev. Force	150.0	0.0	72.0	72.0	0.0 ~ 150.0% of Motor Rated Current	Stall Rev Normal	%
149	Low Spd. Stall Rev. Force	150.0	0.0	72.0	72.0	0.0 ~ 150.0% of Motor Rated Current	Stall Rev Lo Spd.	%
150	Slow Spd SSC	180.0	0.0	2.8	2.8	0.0 ~ 180.0% of Par.27, should be lower than Pr.141	Slow Spd SSC	%
151	HSC Start	100.0	0.0	0.0	0.0	0.0~100.0%	HSC Start	%
152	Hvy Holding Torque	100.0	0.0	82.4	82.4	0.0~100.0% of 1.2 A	Hvy Clo HLD Torq.	A
153(138)	Hvy Holding Speed	180.0	0.0	5.1	5.1	0.0 ~ 180.0% of Par.27, should be lower than Par.159	Hvy Close HLD	%
154(139)	Hvy Holding Start	100.0	0.0	6.0	6.0	0 ~ 100.0 % of Door Width	Hvy HLD Start	%
156	Hvy High Speed Close	180.0	0.0	24.3	24.3	0.0 ~ 180.0% of Par.27, should be lower than Par.185, higher than Par.159	Hvy High HSC	%
157	Hvy Final Speed Close	180.0	0.0	2.8	2.8	0.0 ~ 180.0% of Par.27, should be lower than Par.159	Hvy FSC	%
158(143)	Hvy Final Speed Open Start	100.0	0.0	6.0	6.0	0 ~ 100.0 % of Door Width	Hvy FSC Start	%
159	Hvy Nudging Speed	180.0	0.0	20.00	20.00	0.0 ~ 180.0% of Par.27, should be lower than Pr.156, higher than Par.61, Par.94, Par.96, Par.99, Par.153, Par.157 & Par.150	Hvy Nudg Spd	%
160	Hvy Close Acc. Time	100.0	0.1	1.5	1.5	0.1 ~ 100.0 sec	Hvy Clo. Acc.	sec
161	Hvy Close Dec. Time	100.0	0.1	3.0	3.0	0.1 ~ 100.0 sec	Hvy Clo. Dec.	sec
162	Hvy ACC. Stall Rev. Force	200	100	120	120	100 ~ 200% of Motor Rated Current	Hvy Stall Acc	%
163	Hvy Stall Rev. Force	150.0	0.0	52.0	52.0	0.0 ~ 150.0% of Motor Rated Current	Hvy Stall Normal	%
164	Hvy Low Spd. Stall Rev. Force	150.0	0.0	52.0	52.0	0.0 ~ 150.0% of Motor Rated Current	Hvy Stall Dec Lo Spd.	%
181	Re-Open Detect Time	10.00	0.00	0.05	0.05	0.00~10.00sec	Reopen detect T	sec
182	Fast Dec. Time	10.0	0.1	0.1	0.1	0.1 ~ 10.0 sec	Fastest Dec. TM	sec
185	Max. Close Speed	66.66	0.00	18.00	18.00	0.00 ~ 66.66Hz, should be lower than Par.27, higher than Par.141 & Par.156	Max. Close Spd	Hz
186	Close Timeout	180.0	0.0	0.0	0.0	0.0 ~ 180.0 sec (0.0: disable)	Close Timeout	sec
187	Close Lock Torq. 1	150.00	0.00	60.00	60.00	0.0 ~ 150.0% of Motor Rated Current	Close Lock Torq1	%
188	Close Lock Torq. 2	150.00	0.00	60.00	60.00	0.0 ~ 150.0% of Motor Rated Current	Close Lock Torq1	%
189	Close Holding Time	999.9	0.0	0.0	0.0	0.0 ~ 999.9 sec	Close Hold Time	sec
190	Close Acc S-Curve	10.0	0.0	0.4	0.4	0 ~ 10.0 sec	Close Acc Scurve	sec
191	Close Acc S-Curve 2	10.0	0.0	0.4	0.4	0 ~ 10.0 sec	Close Acc Scurve2	sec

## Digital Input/Output Parameters:

PAR	FUNCTIONS	MAX	MIN	DEFAULT		SETTING	LCD Text	
				C/P	I/O		Description (16bit)	Unit (4 bit)
195	Function Bit	65535	0	1	1	Bit0 0: Reopen when EE triggered	Function Bit	
				1	1	Bit1 0: Reopen when obstruct		
				0	0	Bit2 1: No S-Curve when reopen		
				0	0	Bit3 1: DEMO		
				1	1	Bit4: 1: Standby mode		
196	LED Delay Time	10.00	0.00	3.00	3.00	0 ~ 10.00 sec	LED Delay Time	sec
197	Edges Timeout Delay Time	180.0	0.0	15.0	15.0	0 ~ 180.0 sec	EdgesTimeout DLY	sec
198	Buzzer Delay Time	180.0	0.0	10.0	10.0	0 ~ 180.0 sec	Buzzer Time	sec
202	Detector Edges Mode	2	0	2	2	0: disable 1: NPN 2: PNP	Det. Edges Mode	
203	DCL Reset	1	0	0	0	0: Enable door position reset in DCL 1: Disable door position reset in DCL	DCL Reset	
204	DOL Mode	1	0	1	1	0: DOL is relevant to AUX 1: DOL is irrelevant to AUX	DOL irre. to AUX	
205	Buzzer Mode	2	0	1	1	0: Buzzer Disable 1: Buzzer Enable (Continue) 2: Buzzer Enable (Discontinue)	Buzzer Mode	
206	Edges Timeout Holding Time	180.0	0.0	5.0	5.0	0 ~ 180.0 sec	Edges Timeout HLD	sec
207	Reopen Relay Mode	1	0	0	0	0: EDGES TIMEOUT RELAY is independent from RE-OPEN RELAY 1: EDGES TIMEOUT RELAY is dependent from RE-OPEN RELAY	Reopen Relay MOD	
208	Motor Over-Temperature Protection	1	0	0	0	0: Enable the protection function when the motor is overheated 1: Disable the protection function when the motor is overheated	Motor OH protection	
210	Deme Hold Time	99.99	0.00	2.00	2.00	0~99.99sec	Deme Hold Time	sec

## Protection Parameters:

PAR	FUNCTIONS	MAX	MIN	DEFAULT		SETTING	LCD Text	
				C/P	I/O		Description (16bit)	Unit (4 bit)
215	Software Braking Level	430	350	380	380	350 ~ 430 V	Dynamic Brake Lv	V
216	DC Brake Duty	100	0	50	50	0 ~ 100 %	Dynamic Brake	%
217	Motor Overload Current	8.7	0.0	5.3	5.3	0 ~ 8.7 A	Motor Overload	A
221	Number of Retries	10	0	10	10	0 ~ 10	Auto restart	
222	Retry Waiting Time	120.0	0.1	60.0	60.0	0.1 ~ 120.0 sec	Restart time	sec
228	Electronic Thermal Overload Selection	2	0	2	2	00: Standard Motor 01: Special Motor 02: Disabled	Motor OL Sel	
229	Electronic Thermal Characteristic	600	30	60	60	30 ~ 600 sec	Motor OL Time	sec



## 10. TROUBLESHOOTING GUIDE

Fault Display	Meaning	Reset	Auto Reset	Record	Drive Response	Reset Condition
Over-current	The Output current exceeds 300% of drive's rated current at stop	Yes	Yes	Yes	Coast to Stop	Continuous current must be less than 50% of drive's rated current for 5 seconds
Remedy	1. Verify the wiring of the control circuit and the wiring/grounding of the main circuit to prevent interference 2. Check if other fault codes occur after cycling the power. If yes, return to the factory for repair					

Fault Display	Meaning	Reset	Auto Reset	Record	Drive Response	Reset Condition
Over Voltage	DC Bus Voltage exceeds 405VDC	Yes	Yes	Yes	Coast to Stop	DC-bus must be less than 373.5VDC
Remedy	1. If the DC bus over-voltage occurs due to the regenerative voltage of motor inertia, increase the deceleration time 2. Check if the input voltage is within the rated drive input voltage range, and check for possible voltage spikes 3. Verify the wiring of the control circuit and the wiring/grounding of the main circuit to prevent interference 4. When the drive is at stop, check if the fault codes occurs with 200-240VAC input after cycling the power. If yes, return to the factory for repair					

Fault Display	Meaning	Reset	Auto Reset	Record	Drive Response	Reset Condition
Over Heat	Heatsink temperature exceeds 100° (212°)	Yes	Yes	Yes	Coast to Stop	Heatsink temperature must be less than 95° (203°)
Remedy	1. Ensure that the ambient temperature falls within the specified temperature range 2. Remove any foreign objects from the heatsink and check for possible dirty heat sink fins					

Fault Display	Meaning	Reset	Auto Reset	Record	Drive Response	Reset Condition
Drive Overload	The Output current exceeds 150% of drive's rated current for 60 secs	Yes	Yes	Yes	Coast to Stop	Continuous current must be less than 50% of drive's rated current for 5 seconds
Remedy	1. Check whether the motor is overloaded 2. Reduce torque					

Fault Display	Meaning	Reset	Auto Reset	Record	Drive Response	Reset Condition
OC at Accel	The Output current exceeds 300% of drive's rated current at acceleration	Yes	Yes	Yes	Coast to Stop	Continuous current must be less than 50% of drive's rated current for 5 seconds
Remedy	1. Check for possible poor insulation of the wiring between the U/V/W terminals and the motor 2. Check the motor insulation value with megger. Replace the motor if the insulation is poor 3. Increase the acceleration time 4. The ocA occurs due to the short circuit at the output side of the drive. Check for possible short circuits between the U/V/W terminals with the electric meter. If short-circuits exist, return to the factory for repair					

# MOVFR<sup>3</sup> Door Operator Installation & Adjustment Manual

Fault Display	Meaning	Reset	Auto Reset	Record	Drive Response	Reset Condition
OC at Decel	The Output current exceeds 300% of drive's rated current at deceleration	Yes	Yes	Yes	Coast to Stop	Continuous current must be less than 50% of drive's rated current for 5 seconds
Remedy	<ol style="list-style-type: none"> <li>1. Check for possible poor insulation of the wiring between the U/V/W terminals and the motor</li> <li>2. Check the motor insulation value with megger. Replace the motor if the insulation is poor</li> <li>3. Decrease the deceleration time</li> <li>4. The ocD occurs due to the short circuit at the output side of the drive. Check for possible short circuits between the U/V/W terminals with the electric meter. If short circuits exist, return to the factory for repair</li> </ol>					

Fault Display	Meaning	Reset	Auto Reset	Record	Drive Response	Reset Condition
OC at Steady	The Output current exceeds 300% of drive's rated current at steady state operation	Yes	Yes	Yes	Coast to Stop	Continuous current must be less than 50% of drive's rated current for 5 seconds
Remedy	<ol style="list-style-type: none"> <li>1. Verify the wiring of the control circuit and the wiring/grounding of the main circuit to prevent interference</li> <li>2. Check if other fault codes occur after cycling the power. If yes, return to the factory for repair</li> </ol>					

Fault Display	Meaning	Reset	Auto Reset	Record	Drive Response	Reset Condition
Ground Fault	Short to ground, and drive current is over than 150% Rated Current for 5 secs	No	No	Yes	Coast to Stop	Continuous current must be less than 50% of drive's rated current for 5 seconds
Remedy	<p>When one of the output terminals is grounded, short circuit current is more than 1.5A, the AC motor drive power module may be damaged</p> <ol style="list-style-type: none"> <li>1. Check whether the IGBT power module is damaged</li> <li>2. Check for possible poor insulation at the output line</li> </ol> <p><b>NOTE!</b> The short circuit protection is provided for AC motor drive protection, not for protection of the user</p>					

Fault Display	Meaning	Reset	Auto Reset	Record	Drive Response	Reset Condition
Under Voltage	100~120VAC input: DC Bus Voltage is lower than 180VDC; 200~240VAC input: DC Bus Voltage is lower than 195VDC	Yes	Yes	Yes	Coast to Stop	100~120VAC input: DC Bus Voltage is higher than 210VDC; 200~240VAC input: DC Bus Voltage is higher than 210VDC
Remedy	Adjust the input voltage to the power range of the drive					

Fault Display	Meaning	Reset	Auto Reset	Record	Drive Response	Reset Condition
EEPROM Read Fail	CPU Read Failure	Yes	No	Yes	Coast to Stop	Immediately
Remedy	Return to the factory for repair					

Fault Display	Meaning	Reset	Auto Reset	Record	Drive Response	Reset Condition
Speed Fbk Err	Opposite encoder feedback direction	Yes	Yes	Yes	Coast to Stop	Resets immediately
Remedy	Set Encoder fbk input setting (Pr.45) from 1 to 0 or 0 to 1					

Fault Display	Meaning	Reset	Auto Reset	Record	Drive Response	Reset Condition
Encoder Loss	Encoder feedback loss when running	Yes	Yes	Yes	Coast to Stop	Resets immediately. After resetting: 1. If Pr48 = 2, the drive will continue running at low speed without encoder feedback (PM motor) 2. The drive will continue opening at low speed without encoder feedback. In this scenario, the drive will no longer provide DOL/DCL/DPM signals and will reject any commands from the controller (IM)
Remedy	Check the encoder feedback wiring					

Fault Display	Meaning	Reset	Auto Reset	Record	Drive Response	Reset Condition
Encoder fbk Over spd	Encoder feedback stall	Yes	Yes	Yes	Coast to Stop	Resets immediately
Remedy	<ol style="list-style-type: none"> <li>1. Check the encoder feedback wiring</li> <li>2. Check if the door type (Pr.52) is selected correctly. If not, launch door-learning process (Pr.63 = 1) and ensure the correct door type is selected</li> <li>3. Reset to default. (Pr.02 = 10), launch door-learn process (Pr.63 = 1) and ensure the correct door type is selected</li> </ol>					

Fault Display	Meaning	Reset	Auto Reset	Record	Drive Response	Reset Condition
Encoder fbk dev. Err	Encoder feedback stall	Yes	Yes	Yes	Coast to Stop	Resets immediately
Remedy	<ol style="list-style-type: none"> <li>1. Check the encoder feedback wiring</li> <li>2. Check if the drive provide DOL/DCL when the door is fully opened/closed. If not, launch door-learning process (Pr.63 = 1) again to correct the door width</li> <li>3. Check if the drive provide DOL/DCL when the door is fully opened/closed. If not, verify whether there is any slippage between the belt and the gear during the door's opening and closing motions</li> </ol>					

Fault Display	Meaning	Reset	Auto Reset	Record	Drive Response	Reset Condition
Encoder Ref Loss	Encoder feedback loss (PM Motor), can be detected at stop	Yes	Yes	Yes	Coast to Stop	Resets immediately. If Pr48 = 2, the drive will keep running in low speed without the encoder feedback
Remedy	Check the encoder feedback wiring.					

Fault Display	Meaning	Reset	Auto Reset	Record	Drive Response	Reset Condition
Open Overtime	Door open time is over than Pr.127	Yes	Yes	Yes	Coast to Stop	Resets immediately
Remedy	<ol style="list-style-type: none"> <li>1. Check if the drive provide DOL/DCL when the door is fully opened/closed. If not, launch door-learn procedure (Pr.63 = 1) again to re-learn the door width</li> <li>2. Check if the drive provide DOL/DCL when the door is fully opened/closed. If not, verify whether there is any slippage between the belt and the gear during the door's opening and closing motions.</li> </ol> <p>(Pr.127 is set to 0 by default. When Pr.127 is 0, the drive will not detect the open time)</p>					

Fault Display	Meaning	Reset	Auto Reset	Record	Drive Response	Reset Condition
DoorDir Error	Wrong opening/closing direction during door-learning process	Yes	No	Yes	Coast to Stop	Resets immediately
Remedy	1. Ensure the door is fully closed before initiating the door-learning process 2. Set Encoder fbk input setting (Pr.45) from 1 to 0 or 0 to 1, launch door-learning process (Pr.63 = 1) again					

Fault Display	Meaning	Reset	Auto Reset	Record	Drive Response	Reset Condition
DoorWidth Error	Different door widths for opening and closing were detected during the door-learning process.	Yes	No	Yes	Coast to Stop	Resets immediately
Remedy	1. Check if there is any slippage between the belt and the gear during door-learn process. If yes, decrease Pr.59, launch door-learn procedure (Pr.63 = 1) again 2. Check if the door is fully opened and closed during door-learning process. If not, increase Pr.59, launch door-learn procedure (Pr.63 = 1) again 3. Decrease the Learning Frequency (Pr.62) 4. Verify the door's mechanical alignment and ensure consistent movement during door-learning process					

Fault Display	Meaning	Reset	Auto Reset	Record	Drive Response	Reset Condition
Operate Error	Press "ESC" during door-learning process	Yes	No	Yes	Coast to Stop	Resets immediately
Remedy	N/A					







Copyright © 2025 G.A.L. Manufacturing Company LLC/ A Vantage Company

All rights reserved.

No part of this document may be reproduced in any form, machine or natural without the express written consent of G.A.L. Manufacturing Company LLC.

